



Model U431 (Serial #0 thru 17977)

OWNER'S MANUAL

Manual No. 513568 Dec. 2002, Rev. 5

Need Parts or Service?



We stock the parts you need.
Our Technicians are factory trained and are certified in the Stoelting Technicare program.



CALL
Distributor: _____
Phone No.: _____
(fill in or affix label)



Model No.: _____
Serial No.: _____
Purchase Date: _____
Start-Up Date: _____

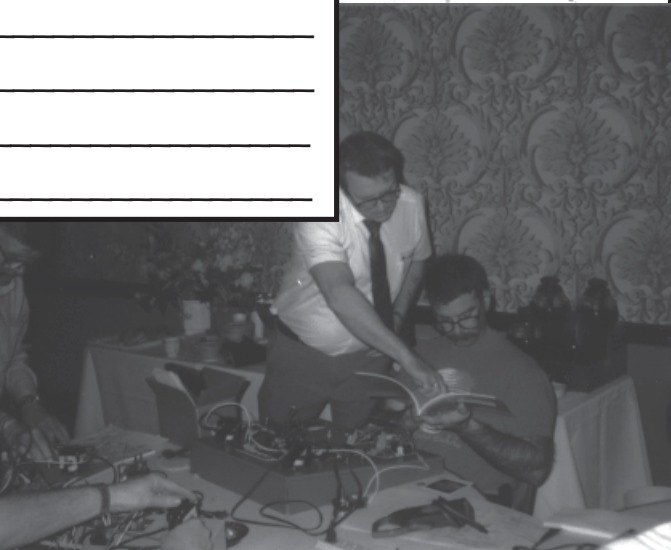
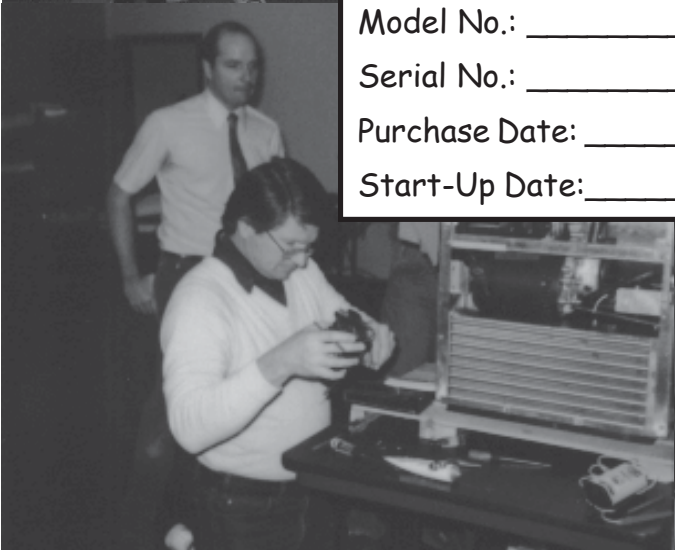

STOELTING® OWNER'S MANUAL
FOR
MODEL U431
CAB MODEL SOFT-SERVE PRESSURIZED FREEZER

This manual provides basic information about the freezer. Instructions and suggestions are given covering its basic operation and care.

The illustrations and specifications are not binding in detail. We reserve the right to make changes at any time without notice, to the freezer and its components, without incurring any obligation to modify or provide new parts for freezers built prior to date of change.

DO NOT ATTEMPT to operate the freezer until instructions and safety precautions in this manual are read completely and are thoroughly understood. If problems develop or questions arise in connection with installation, operation or servicing of the freezer, contact the company at the location listed below.

STOELTING, LLC
502 Hwy 67
Kiel, WI 53042-1600

Tele: 920-894-2293

Fax: 920-894-7029

TABLE OF CONTENTS

Section 1	1
1.1 Description	1
1.2 Specifications	2
Section 2	3
2.1 Safety Precautions	3
2.2 Shipment & Transit	4
2.3 Freezer Installation	4
2.4 Installing Permanent Wiring	4
2.5 Mix Pump	5
Section 3	9
3.1 Safety Precautions	9
3.2 Operating Controls and Indicators	9
3.3 Sanitizing	10
3.4 Initial Freeze Down and Operation	11
3.5 Mix Information	11
3.6 Operation of Mix Pump	11
3.7 Removing Mix from the Freezer	12
3.8 Cleaning the Freezer	12
3.9 Disassembly of Freezer Parts	12
3.10 Routine Cleaning	13
3.11 Mix Pump Cleaning	14
3.12 Sanitize Freezer Parts	14
3.13 Assembly of Freezer	14
Section 4	17
4.1 Freezer Adjustment	17
4.2 Product Temperature Adjustment	17
4.3 Overrun Adjustment	17
4.4 Mix Pump Hose Reposition	18
4.5 Mix Pump Hose Replacement	18
4.6 Cab Temp. Adjustment	18
4.7 Drive Belt Tension Adjustment	18
4.8 Condenser Cleaning (Air Cooled Freezers)	19
4.9 Preventative Maintenance	19
4.10 Extended Storage	19
4.11 Troubleshooting	20
Section 5	25
5.1 How to Order Replacement Parts	25
5.2 Parts Lists and Reference Drawings	25

ILLUSTRATIONS

Figure 1	Model U431 Freezer	1
Figure 2	Specifications	1
Figure 3	Decal Locations	3
Figure 4	Water/Electrical Connections	4
Figure 5	Auger Rotation	4
Figure 6	Mix Hose Installation	5
Figure 7	Mix Pump	6
Figure 8	4 Way Tee	7
Figure 9	Mix Inlet Tube & Probe Assy. Clip	7
Figure 10	Hose Holder	7
Figure 11	Operating Controls	9
Figure 12	Air Bleed Valves	10
Figure 13	Draining Sanitizer	10
Figure 14	Mix Container	11
Figure 15	Mix Pumps	12
Figure 16	Auger Flight Wear & Front Auger Support Bushing Wear	13
Figure 17	Front Door Disassembly	13
Figure 18	Auger Flight Removal	13
Figure 19	Rear Seal Removal	13
Figure 20	Cleaning Feed Tube	14
Figure 21	Cleaning Air Tube	14
Figure 22	Removable Parts	14
Figure 23	Rear Seal Lubrication	14
Figure 24	Spring Installation	15
Figure 25	Front Door Assembly	15
Figure 26	Potentiometer	17
Figure 27	Overrun Adjustment	17
Figure 28	Temperature Control Cab	18
Figure 29	Belt Adjustment	19

SECTION 1 INTRODUCTION

1.1 DESCRIPTION

The Stoelting U431 floor model freezer is pressure fed. The freezer is equipped with fully automatic controls to provide a uniform product. The freezer is designed to operate with almost any type of commercial soft-serve or non-dairy mixes available, including ice milk, ice cream, yogurt, and frozen dietary desserts.

This manual is designed to assist qualified personnel and operators in the installation, operation and maintenance of the Stoelting Model U431 pressure freezer.



Figure 1. Model U431 Freezer

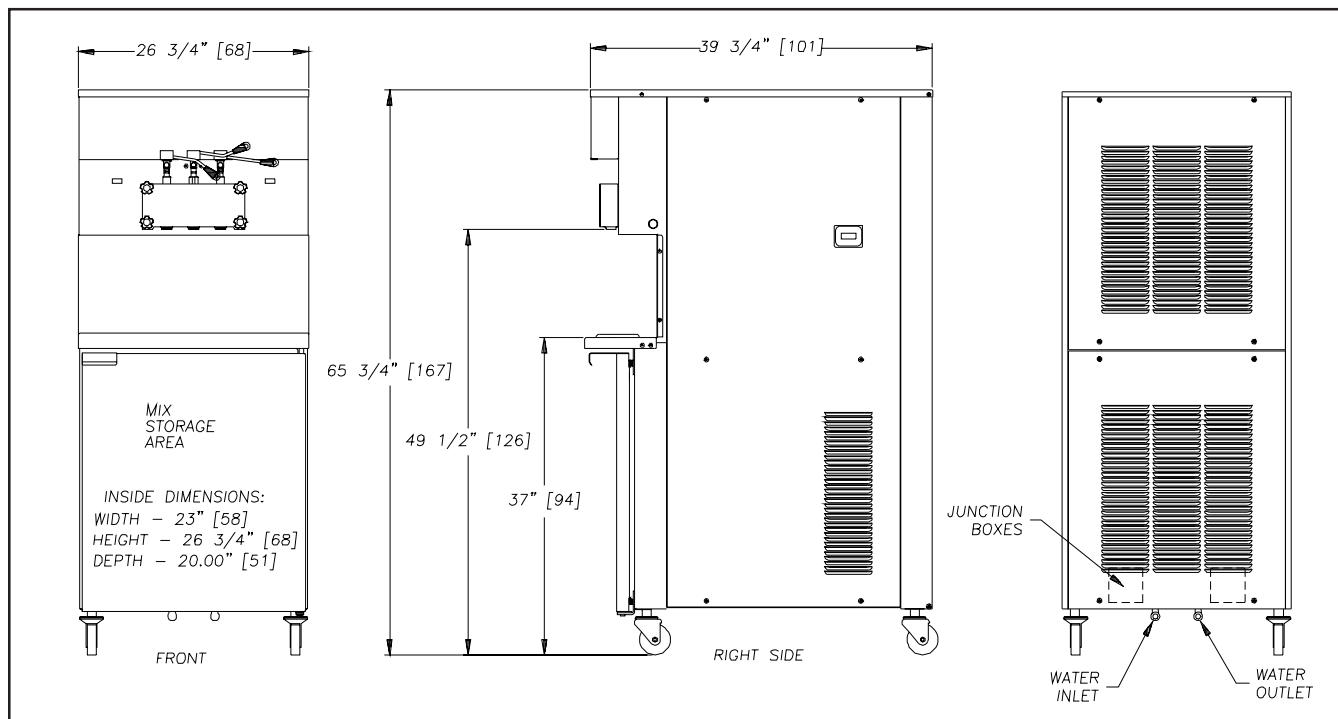

Figure 2. Specification

1.2 SPECIFICATIONS

	MODEL U431									
DIMENSIONS	Width: 26-3/4" (68cm)			Depth: 39-3/4" (101cm)			Height: 65-3/4" (167cm)			
WEIGHT	925lbs. (419,5 kg)					975lbs. w/Crate (442 kg)				
ELECTRICAL (2 separate power sources required.)	1 PH		3 PH		1 PH		3 PH			
	<u>Left Side</u>	<u>Right Side</u>	<u>Left Side</u>	<u>Right Side</u>	<u>Left Side</u>	<u>Right Side</u>	<u>Left Side</u>	<u>Right Side</u>	<u>Left Side</u>	<u>Right Side</u>
Total Running Amps	17.6	17.2	11.6	11.2	20.8	17.2	14.8	11.2		
Minimum Circuit Ampacity	31	31	21	21	36	31	26	21		
HACR Max.Circuit Breaker	45	45	30	30	50	45	35	30		
Maximum Fuse Size	45	45	30	30	50	45	35	30		
COMPRESSOR	11,690 B.T.U.H. each									
DRIVE MOTOR	2 HP each									
COOLING	Water or air cooled. req's 3" (7,5cm) all around clearance and 10" (25cm) top clearance. Water cooled req's 1/2" (12,5mm) NPT water and drain fittings.									

SECTION 2 INSTALLATION INSTRUCTIONS

2.1 SAFETY PRECAUTIONS



WARNING



CAUTION

Do not attempt to operate the freezer until the safety precautions and operating instructions in the manual are read completely and are thoroughly understood.

Take notice of all warning labels on the freezer (Fig.3). The labels have been put there to help you maintain a safe working environment. The labels have been designed to withstand washing and cleaning. All labels must remain legible for the life of the freezer. Labels should be checked

periodically to be sure they have not been painted over, rubbed off, fallen off, and can be recognized as warning labels.

If you are in need of replacement labels, indicate the part number, type of label, location of label, and quantity required along with your name and address and mail to:

**Stoelting, LLC
Commercial Products
502 Hwy. 67
Kiel, WI 53042**

PLACE ITEM (9) & (13) IN SIMILAR LOCATIONS ON OPPOSITE SIDE OF FREEZER.
PLACE ITEM (27) ON INSIDE OF FREEZER ON MOTOR SUPPORT BRACKET.
PLACE ITEM (12) ON INSIDE OF FREEZER ON REDUCER SUPPORT BRACKET (BETWEEN BELTS).
PLACE ITEM (20) ON BACK PANEL & INSIDE OF FREEZER IN-BETWEEN JUNCTION BOXES.
SECURE ITEM (4) WITH ITEM (5) TO CENTER SPIGOT HANDLE.

NOTE:
FOR 4177327-05 USE QTY 1, OMIT ITEM(26) DECAL AND USE ITEM(34) DECAL
FOR 4177327-06 USE QTY 2, OMIT ITEM(26) DECAL AND USE ITEM(34) DECAL

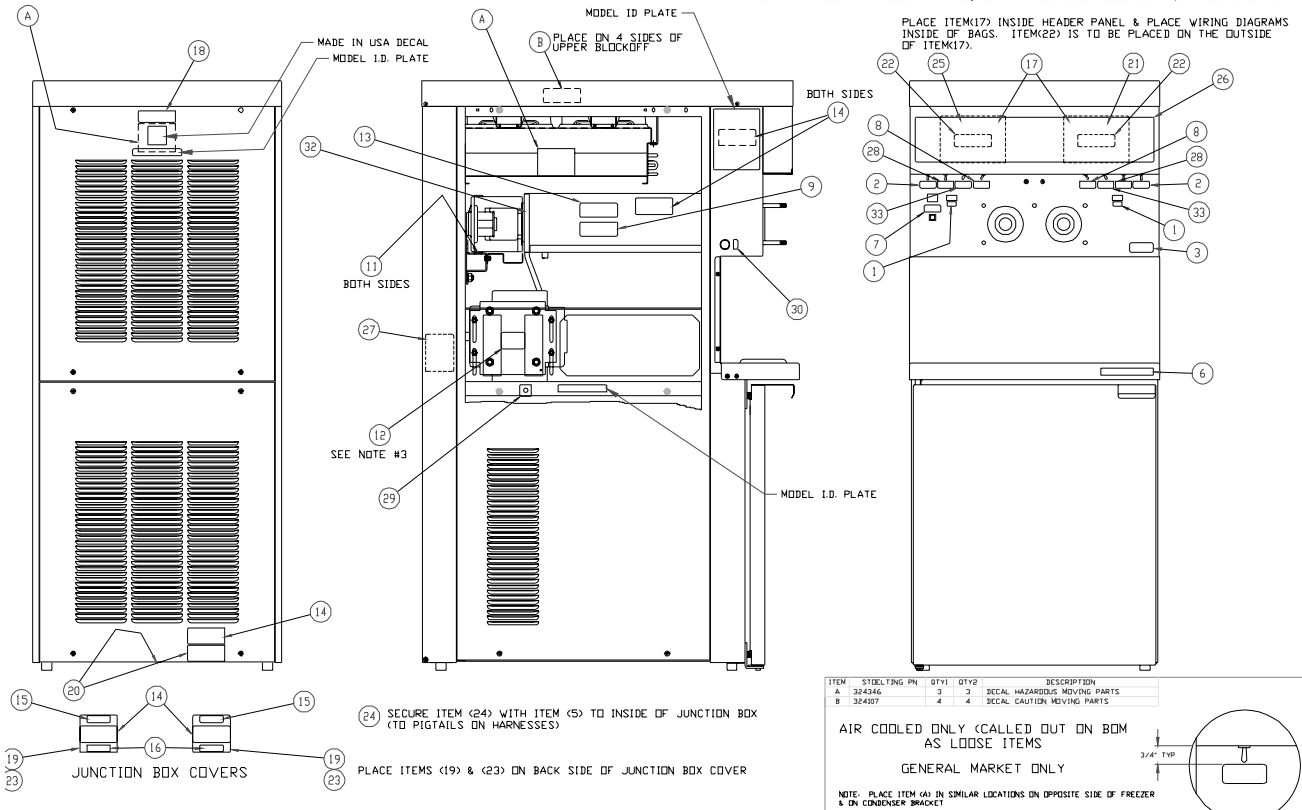

Figure 3. Decal Locations

ITEM	STOELTING PN	QTY		DESCRIPTION
		-03	-04	
1	324801	2	2	DECAL - MIX LOW
2	324798	2	2	DECAL CLEAN-OFF-SERVE SWITCH
3	324141	1	1	DECAL CAUTION-ROTATING BLADES
4	723526	1	1	TAG READ MANUAL & ALL DECALS
5	324346	3	3	DECAL HAZARDOUS MOVING PARTS
6	324393	1	1	DECAL STOELTING SWIRL LOGO
7	324800	1	1	DECAL - CAB ON/OFF
8	324799	2	2	PUMP ON/OFF
9	324208	2	2	DECAL REFRIG LEAK CHECK
10	324509	1	1	DECAL CLEANING (SS & SHAKE)
11	324103	2	2	DECAL CAUTION-ROTATING SHAFT
12	324686	4	4	DECAL DANGER AUTOMATIC START
13	324107	2	2	DECAL CAUTION MOVING PARTS
14	324125	7	7	DECAL ELECT SHOCK HAZARD
15	324151	2	2	DECAL FIELD CONNECTIONS
16	324198	-	2	DECAL ATTENTION INSTALLER
17	130000	2	2	BAG, ENVELOPE FRONT LOADING
18	324584	1	1	DECAL, ADEQUATE VENTILATION (3")
19	324158	2	2	DECAL COPPER CONDUCTORS ONLY
20	324106	2	2	DECAL CAUTION WIRING MAT'L
21	324107	4	4	DECAL CAUTION MOVING PARTS
22	324566	2	2	DECAL - WIRED ACCORDING TO
23	324015	-	2	DECAL 2X1-1/4 BLK ON WHITE
24	723552	2	2	TAG, CAUTION - SUPPLY VOLTAGE
26	324804	1	1	DECAL - GM HEADER (STOELTING SWIRL)
26	324803	1	1	DECAL - GM HEADER (STOELTING LOGO)
26	324806	1	1	DECAL, A&W HEADER FOR U431 & 4231
27	324346	2	2	DECAL-CAUTION HAZARDOUS MOVING
28	324797	2	2	DECAL, STANDBY/SERVE SWITCH
29	324242	1	1	DECAL, TEMPERATURE CONTROL
30	324200	2	2	DECAL, MANUAL RESET
31
32	324014	2	2	DECAL, ARROW
33	314796	2	2	DECAL, FREEZING

2.2 SHIPMENT AND TRANSIT

The freezer has been assembled, operated, and inspected at the factory. Upon arrival at the final destination, the freezer must be checked for any damage which may have occurred during final transit.

With the method of packaging used, the equipment should arrive in excellent condition. THE CARRIER IS RESPONSIBLE FOR ALL DAMAGE IN TRANSIT, WHETHER VISIBLE OR CONCEALED. **Do not** pay the freight bill until the freezer has been checked for damage. Have the carrier note any visible damage on the freight bill. If concealed damage and/or shortage is found later advise the carrier within ten days and request inspection. The customer must place claim for damage and/or shortages in shipment with the carrier. **Stoelting, Inc. cannot make any claims against the carrier.**

2.3 FREEZER INSTALLATION



WARNING

INSTALLATION MUST BE PERFORMED BY A QUALIFIED ELECTRICIAN/REFRIGERATION SPECIALIST. INCORRECT INSTALLATION WILL VOID THE WARRANTY, AND MAY CAUSE SEVERE DAMAGE TO THE MACHINE. MAY CAUSE PERSONAL INJURY.

Installation of the freezer involves moving the freezer close to its permanent location, removing all crating, setting in place, assembling parts, and cleaning.

- A. Uncrate the freezer.
- B. Install the four casters. Turn the threaded end into the freezer until zero threads are showing. To level, turn out casters no more than 1/4" maximum, then tighten all jam nuts.
- C. The freezer must be placed in a solid level position.

NOTE

Accurate leveling is necessary for correct drainage of freezer barrel and to insure correct overrun.

- D. The freezer must have a minimum of 3" (7,5cm) -6" (15cm) high ambient conditions- of space on all sides and 10" (25cm) at the top for proper circulation.



CAUTION

FAILURE TO PROVIDE ADEQUATE VENTILATION WILL VOID WARRANTY!

- E. Water-cooled freezers need an adequate water supply. Install 1/2" (12,7mm) pipe or 1/2" (12,7mm) inside diameter copper water line to the freezer. Connect water outlet to a drain using a 1/2" (12,7mm) inside diameter line. Automatic washer hoses work well for final connections. All water connections must comply with local codes. Fig. 4.



CAUTION

FLUSH ALL WATER LINES BEFORE INSTALLATION. IN STORES WITH SEDIMENT IN WATER, ADD SUITABLE FILTER OR STRAINER TO WATER INLET.

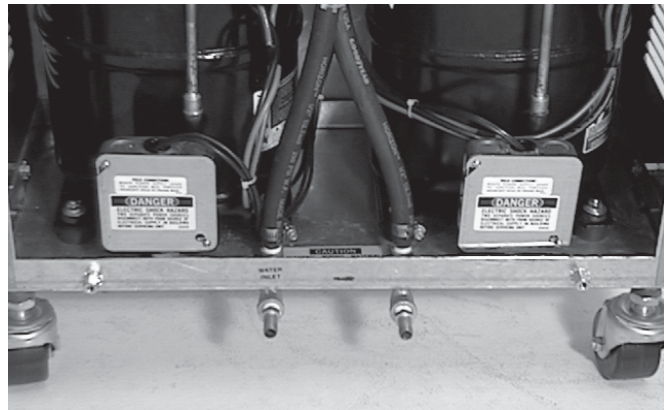

Figure 4. Water/Electrical Connections

- F. Place the CLEAN-OFF-SERVE switches in the OFF position before continuing. Figure 11.

2.4 INSTALLING PERMANENT WIRING

Permanent wiring is required by local codes, the following procedure must be performed:

- A. Refer to the nameplate at the rear of the freezer for specific electrical requirements. Make sure the power source in the building matches the freezer nameplate requirements. Bring the wires into the junction boxes through the access holes in the bottom rear of the freezer. Figure 4.

NOTE

Three phase freezers in areas of unbalanced electrical loads require special attention when connecting input electrical power. The unbalanced leg of power (called wild or high) must be connected to L2 in the junction box.

- B. Remove the lower back panel and the two junction box covers located at the bottom of the freezer.
- C. Install permanent wiring according to local code.
- D. Check the auger shaft rotation by placing the MAIN DRIVE switch in the CLEAN position. Auger shaft rotation is clockwise as viewed through the clear plastic front door. If the rotation is not clockwise, turn main electrical power OFF. Then reverse L1 and L3 electrical power lines to the junction box (three phase only). Re-check auger shaft rotation. Figure 5.

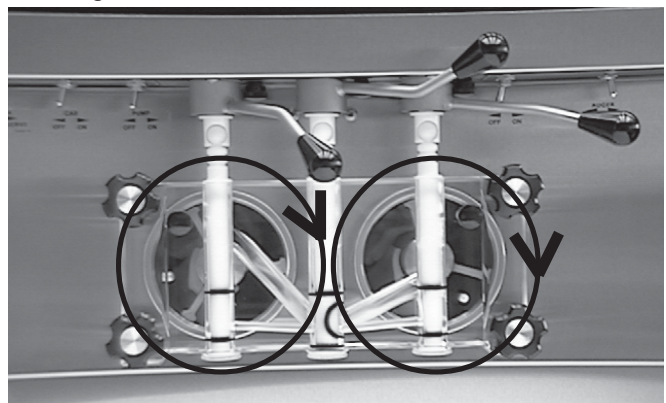

Figure 5. Auger Rotation

2.5 MIX PUMP

A. Mix Pump Hose Installation

Follow the steps below to install the mix pump hose.

1. Turn pump on.
2. Feed one end of mix pump hose into the entering or pick-up hose side (left) of black cover.
3. Gently push the hose into the black cover until it begins to feed.

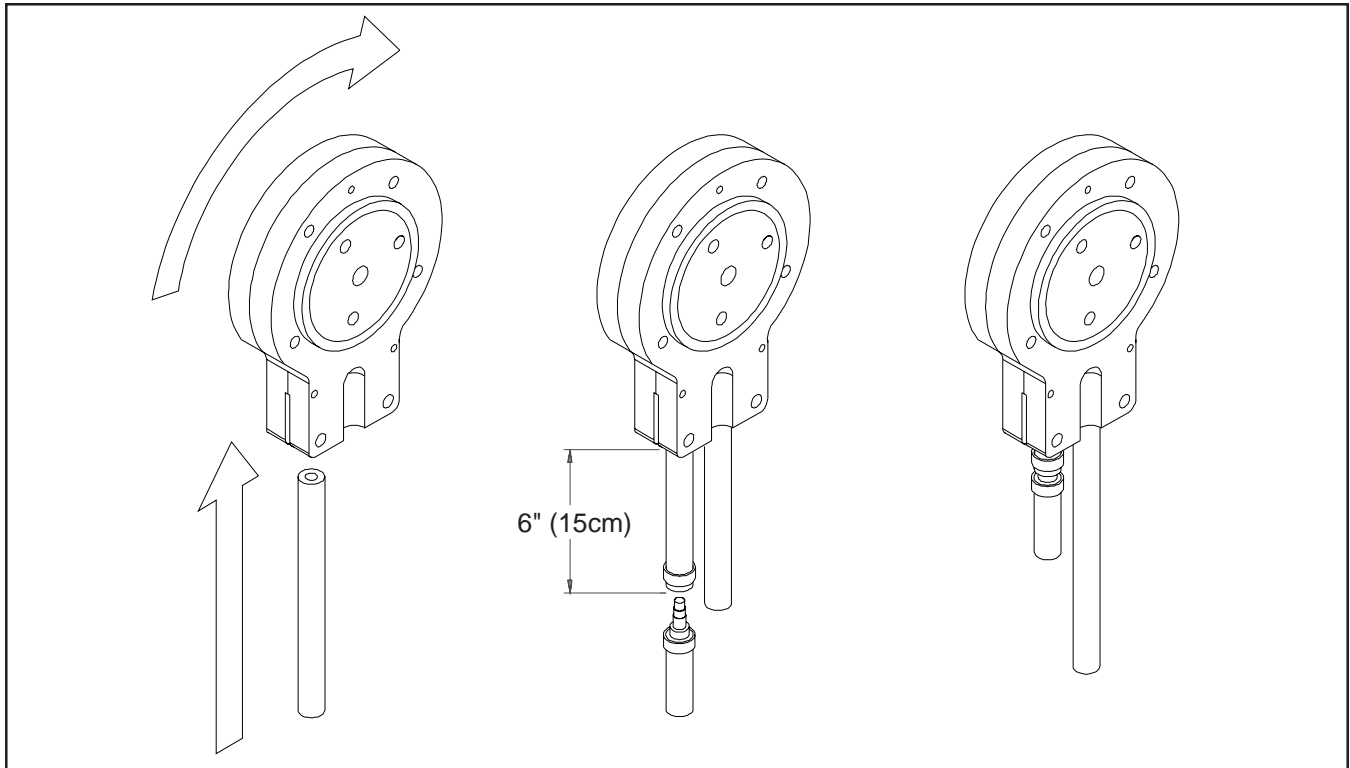
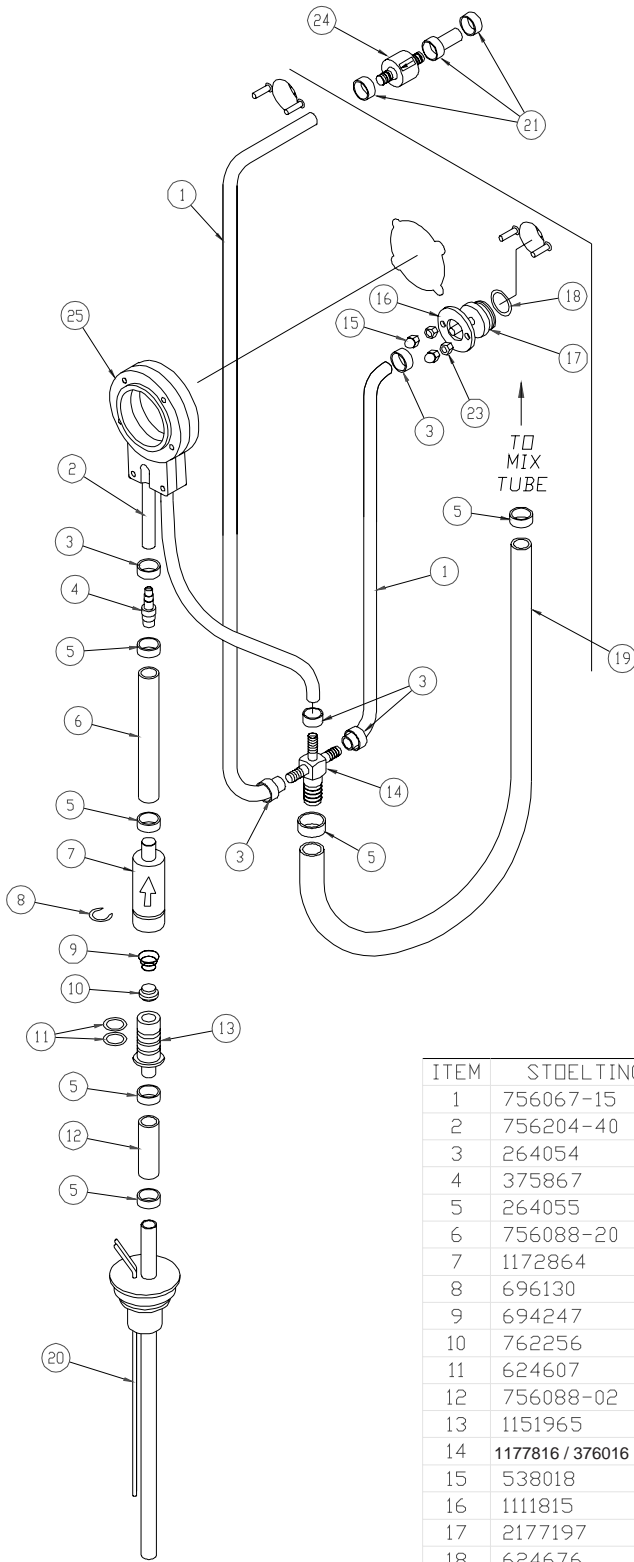

Figure 6. Mix Hose Installation

4. Allow the hose to feed itself thru the pump until 6" (15cm) remains on the entering side.
5. Turn pump off.
6. Connect mix pump hose to pickup hose adapter using small hose clamp.
7. Turn pump on.
8. Allow remaining 6" (15cm) of tubing to feed thru pump until hose adapter prevents further feeding.
9. Turn pump off.
10. Connect free end of mix pump hose to "4 way Tee" as shown in Figure 7. When all connections are complete the "4 way Tee" must be lower than the black pump housing. Figure 8.

 **CAUTION**
DO NOT TWIST MIX PUMP HOSE.



- B. Connect 1/2 inch (12,7mm) I.D. plastic food grade tubing to check valve and then to the mix container. Observe check valve flow arrow. Secure with hose clamps. Then place assembly thru hole in cover and install retainer clip. Figure 9.
- C. Connect 1/2 inch (12,7mm) I.D. plastic food grade tubing between the large port of air/mix tee and refrigerated mix transfer line. Secure with large hose clamp or equivalent. Figure 9.



CAUTION

AIR/MIX TEE MUST REMAIN BELOW THE BLACK COVER/CLAMP. IF THE TEE IS ABOVE THE PUMP MIX WILL DRAIN TO THE AIR COMPRESSOR RESULTING IN PUMP DAMAGE.

- D. Connect mix low cords. Figure 9.

ITEM	STOELTING PN	QTY	DESCRIPTION
1	756067-15	4	TUBING PLASTIC 1/4IDX7/16OD X 15.0" LG
2	756204-40	2	TUBING NORPRENE FOOD .25 ID X 40.0" LG
3	264054	10	CLAMP LOOP JAW TYPE 7/16
4	375867	2	FITTING UNION 1/4"X1/2" BARBED
5	264055	12	CLAMP LOOP JAW TYPE 11/16
6	756088-20	2	TUBING PLASTIC 1/2IDX3/4OD X 20.0" LG
7	1172864	2	VALVE BODY - OUTER
8	696130	2	LOCK CLIP FOR VALVE
9	694247	2	SPRING COMP 13/16X3/8X3/4
10	762256	2	VALVE OUTLET CHECK (MOLDED)
11	624607	4	RING O 11/16X7/8X3/32 SPECIAL
12	756088-02	2	TUBING PLASTIC 1/2IDX3/4OD X 2.0" LG
13	1151965	2	VALVE BODY - INNER
14	1177816 / 376016	2	STAINLESS 4-WAY TEE
15	538018	4	NUT, 10-24 ACORN, 18-8 STN STL
16	1111815	2	LOCKING PLATE WASHER
17	2177197	2	FITTING, PRESSURE SWITCH
18	624676	2	RING O 1-1/8X1-5/16X3/32 70DUR
19	756088-30	2	TUBING PLASTIC 1/2IDX3/4OD X 30.0" LG
20	2177272	2	MIX PICKUP & PROBE ASSY
21	264235	6	CLAMP HOSE 3-8/9-16 MIN/MAX D
22	508135	.001	LUBRICANT, PETRO-GEL 40Z.TUBES
23	538296	4	NUT HEX #10-24 X 38 SS
24	762258	2	CHECK VALVE
25	3171952	2	COVER CLAMP

Figure 7. Mix Pump

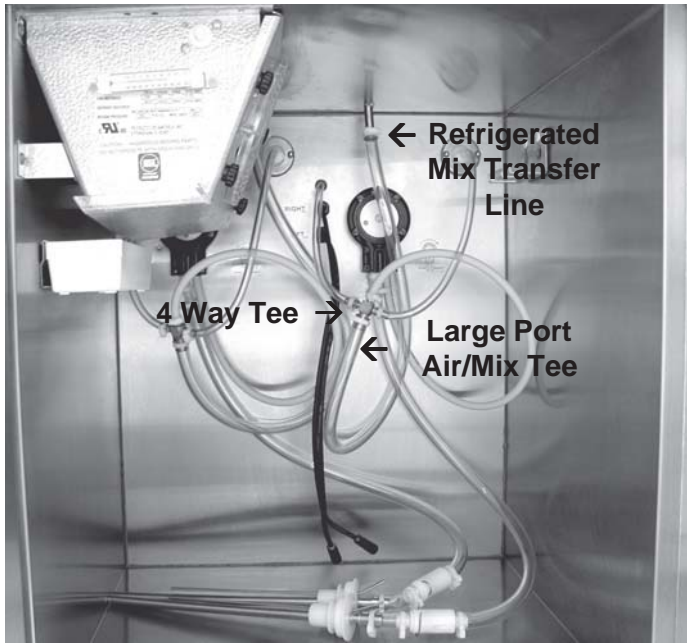

Figure 8. 4 Way Tee

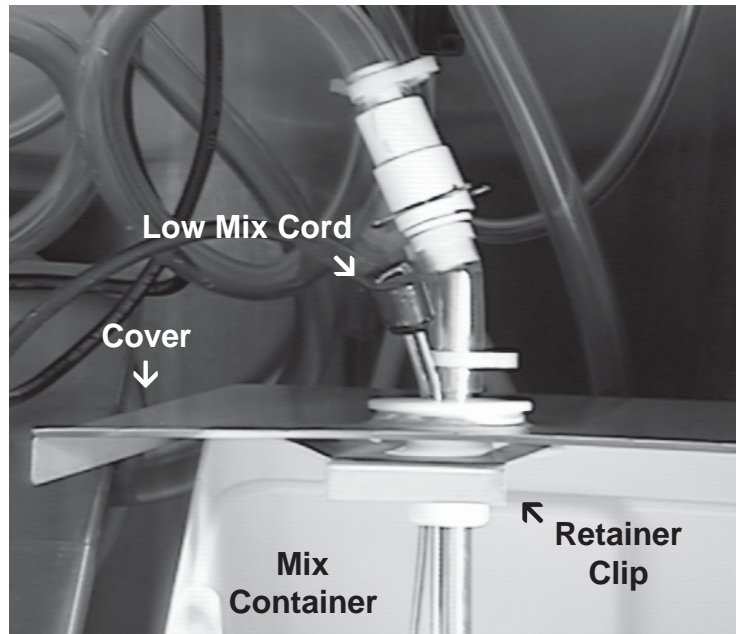

Figure 9. Mix Inlet Tube & Probe Assy. Clip

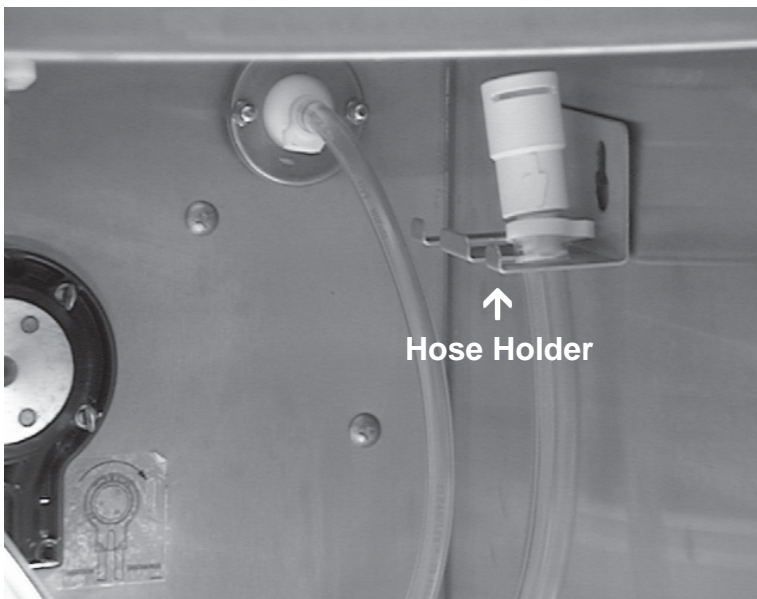

Figure 10. Hose Holder

SECTION 3 INITIAL SET-UP AND OPERATION

3.1 SAFETY PRECAUTIONS

SAFE OPERATION IS NO ACCIDENT; observe these rules:

- A. **Know the freezer.** Read and understand the operating instructions.
- B. **Notice all warning labels on the freezer.**
- C. **Wear proper clothing.** Avoid loose fitting garments, and remove watches, rings or jewelry which could cause a serious accident.
- D. **Maintain a clean work area.** Avoid accidents by cleaning the area and keeping it clean.
- E. **Stay alert at all times.** Know which switch, push button or control you are about to use and what effect it is going to have.
- F. **Disconnect electrical power for maintenance.** Never attempt to repair or perform maintenance on the freezer until the main electrical power has been disconnected.
- G. **Do not operate under unsafe operating conditions.** Never operate this freezer if unusual or excessive noise or vibration occurs.

3.2 OPERATING CONTROLS AND INDICATORS

Before operating the freezer, it is required that the operator know the function of each operating control. Refer to Fig.11 for the location of the operating controls on the freezer.

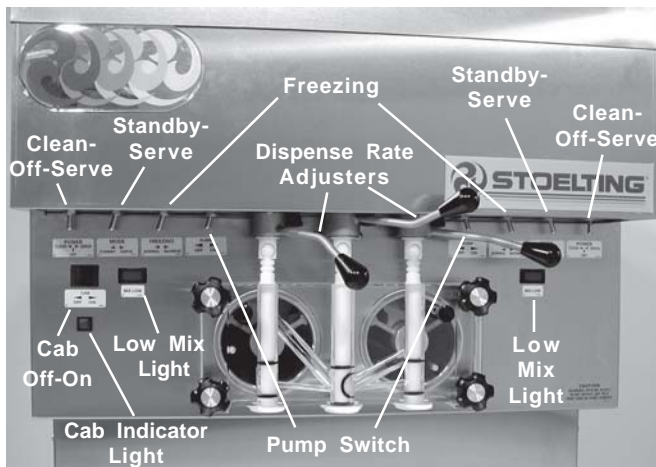

Figure 11. Operating Controls



WARNING

THE CLEAN-OFF-SERVE SWITCH MUST BE PLACED IN THE OFF POSITION WHEN DISASSEMBLING FOR CLEANING OR SERVICING. THE FREEZER MUST BE DISCONNECTED FROM ELECTRICAL SUPPLY BEFORE REMOVING ANY ACCESS PANEL.

A. Spigot Switch

When the spigot handle is opened the SPIGOT switch will start the auger drive and refrigeration systems. When the spigot handle is closed, the drive motor and compressor will remain on until the product in the barrel reaches the proper temperature.

B. Clean-Off-Serve Switch

The CLEAN-OFF-SERVE switch is a three position toggle switch used to control the operation of the refrigeration system and auger. When the switch is placed in the CLEAN position, the refrigeration system will be off and auger **will** rotate for cleaning.

When the switch is placed in the OFF position, the refrigeration system and auger **will not** operate.

When the switch is placed in the SERVE position, the refrigeration system and auger **will** operate automatically. The switch should be placed in the SERVE position for normal operation.

C. Cabinet-Off-On Switch

The CABINET-OFF-ON switch is a two position toggle switch. When the switch is placed in the OFF position, the lower cabinet refrigeration system **will not** run. When the switch is placed in the ON position, the lower cabinet refrigeration system **will** run until the preset temperature is reached; then cycle ON and OFF to maintain that temperature.

D. Cab Indicator Light

A flashing light indicates the cab OFF-ON switch is in the OFF position, no refrigeration. Place the OFF-ON switch in the ON position for cab refrigeration.

E. Pump Switch

The pump motor switch is a two position toggle switch. When the switch is placed in the OFF position, the pump **will not** run. When the switch is placed in the ON position, the pump **will** run until the preset pressure is reached, then cycle ON and OFF as product is drawn to maintain that pressure.

F. Standby/Serve Switch

The standby/serve switch is a two position toggle switch. When the switch is placed in the Standby position the freezer will cycle to maintain a temperature below 41°F. When the switch is in the Serve position the freezer will cycle to maintain a servable product.

G. Freezing Switch

The freezing switch is a two position toggle switch. When the switch is placed in the ON position the freezer will be forced to run 30 seconds after the temperature control is satisfied.

H. Dispense Rate Adjusters

The dispense rate adjuster limits the opening of the spigot. To adjust product dispense rate, turn the adjusting knob clockwise for slower flow and counter-clockwise for faster flow.

I. High Head Pressure Cut Out

If the head pressure exceeds 445 PSIG (28 bar) air cooled and water cooled, the high head pressure cutout will trip. The reset button can be accessed from the side of the freezer.

J. Low Mix Light

The low mix light will illuminate when the liquid level in the mix container drops below two gallons.

K. Front Door Safety Switch

The front door safety switch prevents the auger from turning when the front door is removed. The switch is open when the door is removed and closed when the door is properly installed.

3.3 SANITIZING

Sanitizing must be done after the freezer is clean and just before the freezer is filled with mix. **Sanitizing the night before is not effective.** However, you should always clean the freezer and parts after using it.



WARNING

THE UNITED STATES DEPARTMENT OF AGRICULTURE AND THE FOOD AND DRUG ADMINISTRATION REQUIRE THAT ALL CLEANING AND SANITIZING SOLUTIONS USED WITH FOOD PROCESSING EQUIPMENT BE CERTIFIED FOR THIS USE.

When sanitizing the freezer, refer to local sanitary regulations for applicable codes and recommended sanitizing products and procedures. The frequency of sanitizing must comply with local health regulations. Mix sanitizer according to manufacturer's instructions to provide a 100 parts per million strength solution. Mix sanitizer in quantities of no less than 2 gallons of 120°F water. Allow sanitizer to contact the surfaces to be sanitized for 5 minutes. Any sanitizer must be used only in accordance with the manufacturer's instructions.

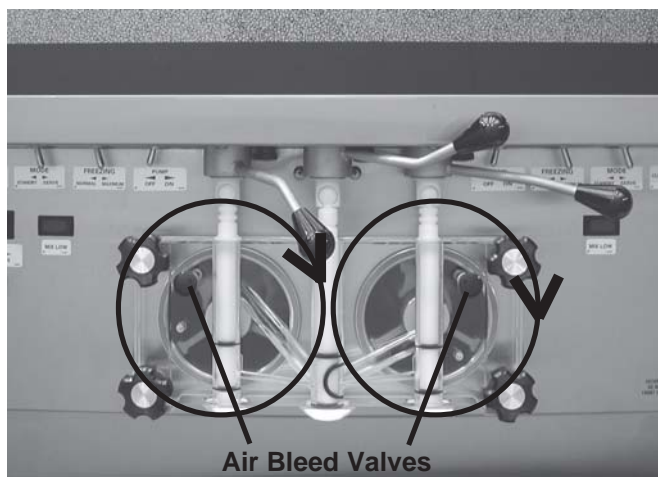

Figure 12. Air Bleed Valves



CAUTION

PROLONGED CONTACT OF SANITIZER WITH FREEZER MAY CAUSE CORROSION OF STAINLESS STEEL PARTS.

In general, sanitizing may be conducted as follows:

- A. Clean and lubricate parts.
- B. Prepare 3 gallons of sanitizing solution following manufacturer's instructions, and pour into storage container.
- C. Place the mix pump switch in the ON position and open air bleed valve on the front door by pushing valve in and holding. Figure 12.
- D. Let sanitizing solution fill the freezer barrel to air bleed valve, then close the valve by pulling out to lock in place.
- E. Place the CLEAN-OFF-SERVE switch in the CLEAN position.
- F. Check for leaks when the freezer barrel is first pressurized with sanitizing solution.
 - 1. Check for leaks at the plastic front door, the O-rings may not be sealed.
 - 2. Check the drain tray located at the right or left side of the freezer for leaks.
 - 3. Check inside cab unit for leaks at hose connections and manifolds.
- G. Using a sanitized soft bristle brush or equivalent, dipped in sanitizing solution, clean mix container.
- H. After five minutes, open spigot to expel sanitizing solution. Drain all solution from freezer using all three spigots. Figure 13.



Figure 13. Draining Sanitizer

- I. Close the spigot and place the mix pump switch and the CLEAN-OFF-SERVE switch in the OFF position.

The freezer is now sanitized and ready for adding mix.

3.4 INITIAL FREEZE DOWN AND OPERATION

This section covers the recommended operating procedures to be followed for the safe operation of the freezer.

- A. Sanitize just prior to use according to instructions.
- B. Prepare the desired amount of mix and then fill storage container with approximately 3 gallons or more of mix. Place a container(s) of mix in the cooler. If drawing from a storage container, place the draw tube through the cover to the bottom of the container. If drawing from a bag in a box, remove the cap, push out all of the air, and insert the adaptor.



Figure 14. Mix Containers

- C. Place the mix pump switch, located on the front of the freezer, in the ON position. Immediately open the spigot and let approximately 8 ounces of liquid mix with sanitizing solution drain out of the spigot.
- D. Close the spigot and open the air bleed valve on the front door by pushing the valve in and holding. Allow the barrel to fill until the mix level is 1/2 inch below air bleed valve, then release valve and pull closed to lock in place.
- E. Start the compressor and drive by placing the CLEAN-OFF-SERVE switch in the SERVE position.
- F. The product will be ready to serve after the compressor and drive have cycled off, or in approximately 12 minutes.
- G. The refrigeration is automatically actuated when the spigot is opened. For normal dispensing, open the spigot no more than 90°. (This is when the handle knob is pointed directly away from the front door.) This position provides excellent control over the product and aids in making desired shaped portions. Close spigot completely after dispensing.

It is possible to overdraw if rate of draw is exceeded for extended periods. If the freezer is overdrawn, the result will be a soft product and air pops. To draw a quart properly, it is necessary to use a little more than one minute.

During normal operation it is not necessary to be overly concerned about capacity. But, if there is an order for six products at one time, each using 9 ounces of product, it should be considered as 54 ounces of product. Approximately two minutes must be allowed for this drawing. After a while most operators will sense, or feel, when the freezer is beginning to fall behind, and will slow up on the rate of draw so as not to exceed capacity.

3.5 MIX INFORMATION

Mix can vary considerably from one manufacturer to another. Differences in the amount of butter-fat content and quantity and quality of other ingredients have a direct bearing on the finished frozen product. A change in freezer performance that cannot be explained by a technical problem may be related to the mix.

Proper product serving temperature varies from one manufacturer's mix to another. Mixes should provide a satisfactory product in the 17° to 20°F range.

When checking the temperature, stir the thermometer in the frozen product to read the true temperature.

Mix does not improve with age. Old mix, or mix that has been stored at too high a temperature, can result in a finished product that is less than satisfactory from the appearance and taste standpoint. To retard bacteria growth in dairy based mixes, the best storage temperature range is between 36° to 40°F.

3.6 OPERATION OF MIX PUMP

The PUMP switch is located on the front of the freezer. When the pump switch is placed in the ON position, the mix pump motor will be actuated to pump mix into the freezer cylinder. When the set pressure is reached, the mix pump will shut off automatically. When the switch is placed in the OFF position, the mix pump will be inoperative.

NOTE

The mix pump motor is equipped with an internal overload that will "kick-out" when the motor is overloaded. Consult the trouble shooting section for corrective information. The internal overload will automatically reset after cooling. If the condition continues, contact a qualified service person.

The pump hose must be repositioned every 1 - 2 weeks or 60 hours of operation. Failure to comply will result in reduced mix pump liquid capacity, dispense stoppage, popping, and possible mix pump hose leakage.

Find a system that works for you. Operating until hose breaks shortens pump life, causes downtime and increases cleaning costs.

- A. Mix Operation: The peristaltic mix pump contains one continuous mix pump hose. When looking at the face of the peristaltic mix pump, the left side of the hose is the suction or pickup. The right side of the hose is the discharge. Mix is drawn up the suction side of the hose and transferred thru the discharge side to the freezer. Figure 15.

- B. Air Operation: The air compressor operates concurrently with the peristaltic mix pump. Air enters thru a check valve on the piston downstroke. The air is discharged thru a second check valve, on the piston upstroke. The air and mix join at the tee and then travel to the freezer.

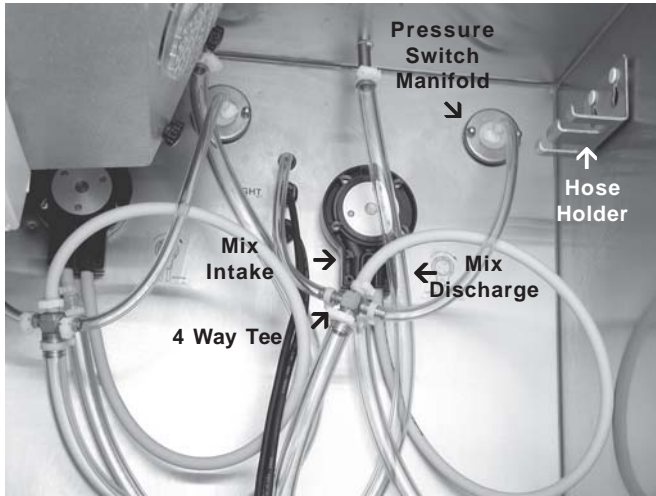

Figure 15. Mix Pumps

- C. The over-run adjustment is preset at the factory. If an adjustment becomes necessary, refer to Section 4.

3.7 REMOVING MIX FROM THE FREEZER

This cleaning procedure must be followed each time the freezer is to be shut off for an extended period of time such as overnight or on non-business days.

- A. Place the mix pump in the OFF position.
- B. Draw desired frozen mix from freezer. Close spigot.
- C. Place CLEAN-OFF-SERVE switch in CLEAN position. Allow mix to agitate in freezer barrel until the mix has become liquid.
- D. Place the mix pump in the SERVE position. Open spigot and pump liquid mix through the freezer. When empty, place CLEAN-OFF-SERVE switch and the mix pump switches in the OFF position. Figure 12.
- E. Close the spigot and place the mix pump suction tube into the pail of cold tap water.
- F. Open air bleed valve on the front door by pushing valve in and holding.
- G. Place the mix pump switch in the ON position.
- H. Let the cold water fill freezer to air bleed valve, then close the valve by pulling out to lock in place.
- I. Place the CLEAN-OFF-SERVE switch in the CLEAN position.

- J. Allow water to agitate until the inside surface of front door has rinsed clean.
- K. Open spigot to expel water. When the pail is empty, place the mix pump switch and CLEAN-OFF-SERVE switch in the OFF position. Allow freezer barrel to drain completely.

3.8 CLEANING THE FREEZER

NOTE

The frequency of cleaning the freezer and freezer parts must comply with local health regulations.

After the mix has been removed from the freezer, the freezer must be cleaned. To clean the freezer, refer to the following steps:

- A. Close the spigot and fill the barrel with cold tap water.
- B. Place the CLEAN-OFF-SERVE switch in the CLEAN position.
- C. Allow the water to agitate for approximately five minutes.
- D. Open the spigots to drain the water. Remember to place a bucket or container under the spigots to catch the water. Repeat this process using a total of 2 gallons of cold tap water. When the water has drained, turn the CLEAN-OFF-SERVE switches to the OFF position. Allow the freezer barrel to drain completely.
- E. Repeat steps A through D using a mild detergent solution.
- F. Repeat steps A through D using 120° to 130°F hot rinse water.

3.9 DISASSEMBLY OF FREEZER PARTS



CAUTION

PLACE THE CLEAN-OFF-SERVE TOGGLE SWITCH IN THE OFF POSITION BEFORE DISASSEMBLING FOR CLEANING OR SERVICING.

Inspection for worn or broken parts should be made at every disassembly of the freezer for cleaning or other purposes. All worn or broken parts should be replaced to ensure safety to both the operator and the customer and to maintain good freezer performance and a quality product. Two normal wear areas are the auger flights and front auger support bushing. Figure 16. Frequency of cleaning must comply with the local health regulations.

To disassemble the freezer, refer to the following steps:

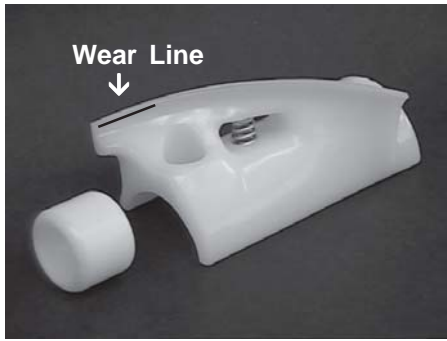

Figure 16. Auger Flight Wear & Front Auger Support Bushing Wear

A. Disassembly Of Front Door.

1. Remove the front door by turning off the circular knobs and then pulling the front door off the studs.



CAUTION
HAZARDOUS ROTATING BLADES-DO NOT OPERATE UNIT WITH FRONT DOOR OR SPIGOT REMOVED.

2. Remove the air bleed valve by unscrewing the knob while holding the valve stem from behind. Remove the compression spring and push air bleed valve through the rear of the front door.
3. Remove the spigot through the bottom of the front door. Figure 17.

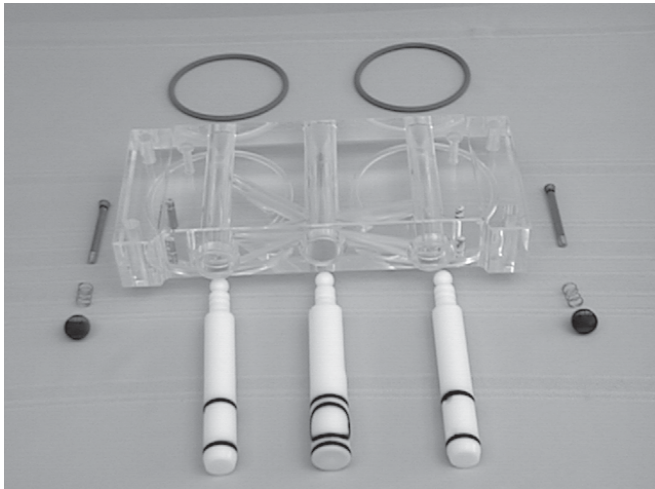

Figure 17. Front Door Disassembly

B. Disassembly Of Auger

1. Remove the front auger support by pulling it straight out of the freezer barrel.
2. Remove the plastic bearing from the front auger support.
3. Remove the auger by pulling slowly and rotating out of the freezer barrel. As the auger is with drawn, remove each plastic flight and spring from the auger. Figure 18.



Figure 18. Auger Flight Removal

NOTE

Be careful not to scratch inside of freezer barrel when removing flights or auger.

4. Keep the rear of the auger tipped up once it is clear of the freezer barrel.
5. Wipe spline lubricant off hex end of auger with a paper towel.
6. Remove the rear seal. Figure 19.

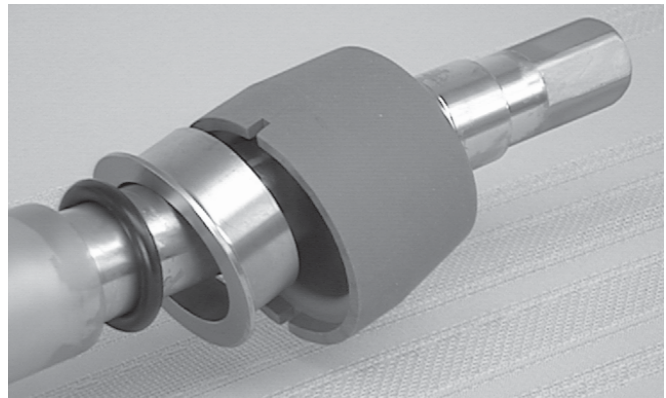

Figure 19. Rear Seal Removal

3.10 ROUTINE CLEANING

A good grade of stainless steel has been used on the freezer to ease clean-up. To remove spilled or dried mix, simply wash the exterior in warm, soapy water and wipe dry. Do not use highly abrasive materials as they will mar the finish.

- A. To clean the freezer parts, disassemble all parts. (Refer to section 3.9 for the disassembly of freezer parts.)
- B. Place all parts in warm, mild detergent water and wash thoroughly. Rinse all parts with clean **hot** water.

NOTE

Take care not to damage parts by dropping or rough handling.

- C. Wash feed tube and freezer barrel with warm detergent water and brushes provided. Rinse with clean, hot water. Figure 20.

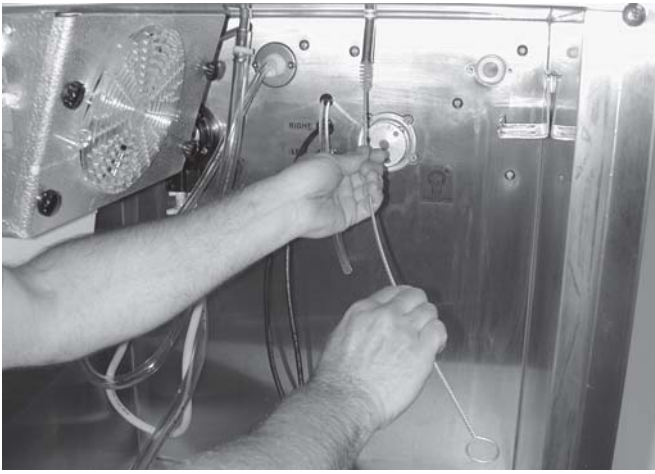

Figure 20. Cleaning Feed Tube

- D. Clean the rear seal surface from inside of the freezer barrel.
- E. Remove the rear drip tray by pulling from side panel. Clean and replace drip tray.
- F. Assemble freezer parts. (Refer to section 3.13 for assembly of freezer parts).

NOTE

Any cleaning procedure must always be followed by sanitizing before filling freezer with mix. (Refer to section 3.3)

3.11 MIX PUMP CLEANING

The mix pump is approved for CIP (clean in place) and is thoroughly cleaned as cleaning solutions are pumped thru the freezer. We recommend completely disassembling the pump and connecting tubing every 14 days for inspection of parts to confirm the CIP has been properly performed. If any residue is detected clean or replace those parts. Clean parts in warm soapy water using brushes provided. See Figures 21 and 22.

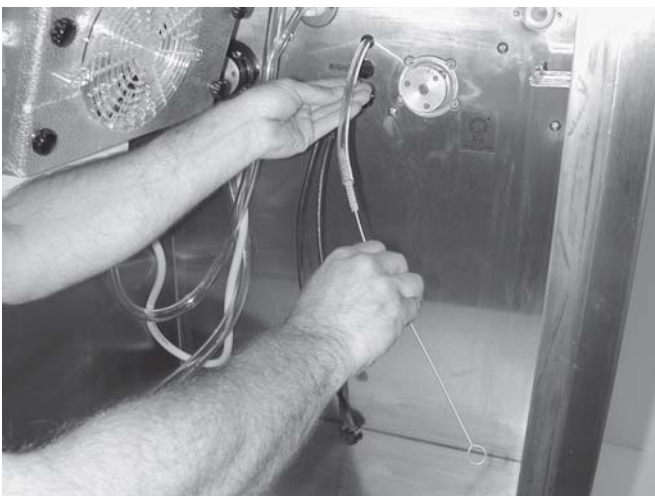

Figure 21. Cleaning Air Tube



Figure 22. Removable Parts

3.12 SANITIZE FREEZER PARTS

- A. Use a sanitizer mixed according to manufacturer's instructions to provide a 100 parts per million strength solution. Mix sanitizer in quantities of no less than 2 gallons of 120°F water. Allow the sanitizer to contact the surfaces to be sanitized for 5 minutes. Any sanitizer must be used only in accordance with the manufacturer's instructions.
- B. Place all parts in the sanitizing solution, then remove and let air dry.
- C. Using this sanitizing solution and the large barrel brush provided, sanitize the barrel by dipping the brush in the sanitizing solution and brushing the inside of the barrel.

3.13 ASSEMBLY OF FREEZER

To assembly the freezer parts, refer to the following steps:

NOTE

Petro-Gel sanitary lubricant or equivalent must be used when lubrication of freezer parts is specified.

NOTE

The United States Department of Agriculture and the Food and Drug Administration require that lubricants used on food processing equipment be certified for this use. Use Lubricants only in accordance with the manufacturer's instructions.

- A. Assemble all "O" rings onto parts dry, **without lubrication**. Then apply a thin film of sanitary lubrication to exposed surfaces of the "O" rings.
- B. Lubricate rear seal area on auger with a thin layer of sanitary lubricant. Install the rear seal (Figure 23) "O" ring. Lubricate and install rear seal.

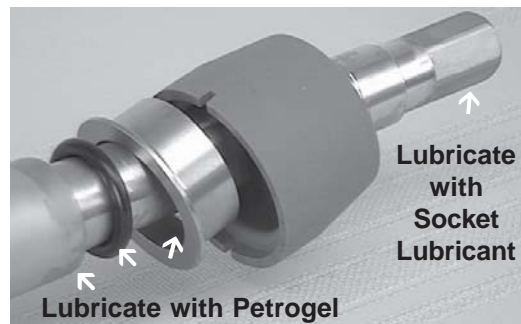

Figure 23. Rear Seal Lubrication

- C. Lubricate the hex drive **end** of auger with a small amount of white socket lubricant. A small container of socket lubricant is shipped with the freezer.
- D. Screw the springs onto the studs in plastic flights. **Spring must be screwed into the flights completely** to provide proper tension. Figure 24.



Figure 24. Spring Installation

- E. Install first flights to bottom of auger, rotate, add successive flights from bottom as the auger is pushed slowly into the freezer barrel. Carefully engage auger with drive socket in speed reducer by rotating auger slowly and pushing on end of auger.
- F. Apply a thin film of sanitary lubricant to the inside and outside of the front auger support bearing, then place on the front of the auger. Assemble the front auger support onto the auger bearing.

NOTE

Position the front support on auger so legs do not interfere with the pin on the back of the front door assembly. Front door must push auger in slightly when it is being tightened to prevent the rear seal from leaking.

- G. Assemble "O" rings onto the spigot dry, without lubrication. Then apply a thin film of sanitary lubricant to the outside of the "O" rings and spigot bodies.
- H. Install the spigots through the bottom of the front door. Figure 25.

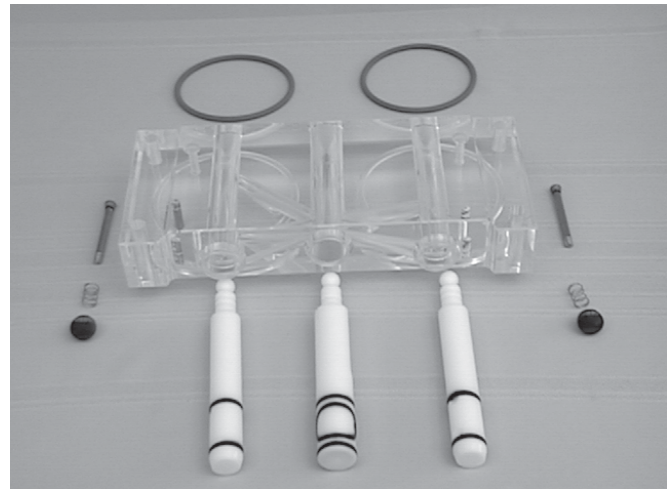

Figure 25. Front Door Assembly

- I. Assemble the air bleed valve "O" ring onto the air bleed valves. Position the "O" ring in groove close to the wide part. Apply a thin film of sanitary lubricant to the "O" rings.
- J. Insert the air bleed valves from the back of the front door. Install compression springs onto air bleed valves, then screw on knobs finger tight.
- K. Apply a thin film of sanitary lubricant to the door seal "O" rings, and fit into the grooves on the rear of the front door.
- L. Place the front door assembly on the mounting studs and push front door against the freezer carefully.
- M. Secure front door assembly by placing the knobs on the studs and alternately tighten opposite corners until **finger tight only**. Do **not** overtighten. Proper "O" ring seal can be observed through the transparent front door.
- N. Move the spigot handles to the closed position.

SECTION 4 MAINTENANCE INSTRUCTIONS

4.1 FREEZER ADJUSTMENT

This section is intended to provide maintenance personnel with a general understanding of the freezer adjustments. It is recommended that any adjustments in this section be made by a qualified person.

4.2 PRODUCT TEMPERATURE ADJUSTMENT

A potentiometer is used to control the product temperature. To change the temperature of the product, follow the steps below:

- A. Loosen the two screws under the header display sign, then pull sign out and down.
- B. Use a screw driver to make desired adjustment. A label near the potentiometer will give complete instructions. Figure 26.

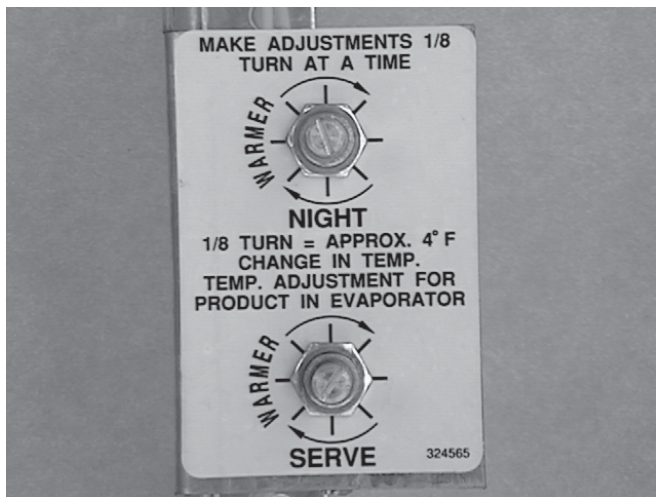

Figure 26. Potentiometer

4.3 OVERRUN ADJUSTMENT

The product when served is a combination of air and mix. Overrun is a measure of the amount of air blended into the mix.

Overrun can be expressed in terms of the amount of weight loss for a given volume. For example, if a pint of liquid mix weighs 18 ounces (510 grams) and a pint of frozen product with air added weighs 12 ounces (340 grams), the overrun is said to be 50 percent "18 oz. (510 grams) - 12 oz. (340 grams) = 6 oz. (170 grams)", $(6/12) \times 100 = 50\%$.

The overrun can be checked by placing a one pint container on an ice cream scale and zeroing out the scale. Then fill a one pint container with frozen product. The container should be filled over the top and leveled with a straightedge. The product should not contain any air pockets. When weighed on an ice cream scale, one pint (473 milliliters) of product should weigh 12 to 13 ounces (340 to 368,5 grams).

The mix pump has been preset at the factory to produce a product with approximately 40% overrun. Because of differences in mix formulation, temperatures and barometric pressure, this figure may vary. It will be necessary for approximately 2 gallons (7,5 liters) of mix to be pumped thru the freezer before changes in the product are noticeable due to adjustments in overrun.

Overrun is controlled by the length of the air compressor piston stroke within the piston cylinder. Lengthening the stroke within the cylinder will increase overrun. Conversely, shortening the stroke will decrease overrun. To perform an overrun adjustment, refer to the following procedure:

- A. Turn the mix pump switch to the OFF position. Disconnect both power sources/circuit breakers.
- B. Remove the lower back panel from freezer.
- C. On air compressor side of pump, locate the long/slender piston rocking arm. The rocking arm downward travel is limited by a stationary cam. On the face of the cam there is an overrun setting indicator plate numbered 3 thru 8 and an adjustment knob. Figure 27.

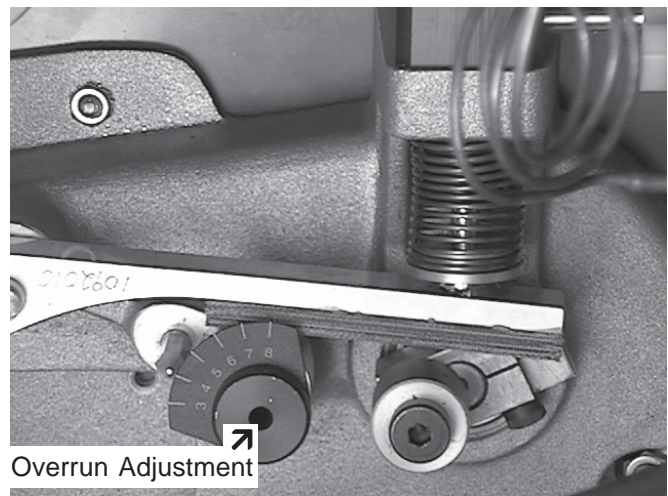

Figure 27. Overrun Adjustment

- D. The overrun setting is indicated by a pointed pin.
- E. To adjust overrun, loosen the allenhead screw (located within the center of the adjustment knob) with the 5/32" (4mm) allen wrench provided. Rotate the adjustment knob counterclockwise to a higher number for higher overrun, or clockwise to a lower number for lower overrun. Each number multiplied by 10 represents the overrun percentage (ie: #4 = 40% overrun).

F. Tighten the allen screw, then place the wrench back in its clip. Replace the lower back panel and secure with the four screws. Turn the mix pump power switch to the ON position.

4.4. MIX PUMP HOSE REPOSITION (every one or two weeks.)

NOTE

Mix pump hose must be repositioned every 1 - 2 weeks. Failure to comply will result in reduced mix pump liquid capacity, dispense stoppage, popping, and possible mix pump hose leakage.

1. Run cleaning solution through pump.
2. Turn pump off and relieve any pressure by opening the spigot.
3. Grasp the pick-up hose end of the mix pump hose with one hand and turn the pump on. Pull down on the pick-up hose end until 12 to 14" (30-1/2 to 35-1/2cm) of tubing has reverse fed through the pump, then turn the pump off.
4. Loosen small clamp at the pick-up hose adapter and (Viewed from Back) disconnect mix pump hose.
5. Cut 7-1/2" (19 cm) off the end of the mix pump hose.
6. Reconnect mix pump hose to adapter.
7. Continue normal operation. Mix hose will automatically reposition itself with adapter near black cover.

NOTE

Each hose is long enough for 3 repositions before replacement is required. Record each event on Hose Service Record decal.

4.5 MIX PUMP HOSE REPLACEMENT

NOTE

Mix pump hose must be replaced when tubing cannot be further repositioned (every four to eight weeks). Failure to comply will result in hose failure and possible pump damage.

1. Run cleaning solution through pump.
2. Turn pump off and relieve any pressure by opening the spigot.



WARNING

THE MIX PUMP SWITCH MUST BE IN THE "OFF" POSITION WHEN SERVICING OR CLEANING PUMP.



CAUTION

NEVER DISCONNECT HOSES FROM FREEZER OR PUMP WITHOUT FIRST OPENING SPIGOT TO RELIEVE PRESSURE.

3. Disconnect mix pump hose at each end.
4. Grasp the discharge hose end with one hand and turn the pump on. Pull down on the hose until all of the remaining hose is removed from the pump.
5. Connect new mix pump hose to pick-up hose adapter, using small clamp.
6. Insert free end of hose into the pick-up (suction side) hose side of the black cover. Gently push the hose into the black cover until it begins to self-feed. Allow the hose to feed itself through the pump until the pick-up hose adapter prevents further feeding, then turn the pump off.
7. Reconnect mix pump hose to T using small clamp. Pump is now ready to sanitize.

4.6 CAB TEMPERATURE ADJUSTMENT

A temperature control is used to control cab temperature. To change the temperature, disconnect electrical power and then follow the steps below:

- A. Remove the six screws holding the left side panel and remove panel.
- B. Use a small screwdriver to adjust the temperature control. Turn counterclockwise for a warmer temperature and clockwise for a colder temperature. It will take about an hour for the cab temperature to change. Figure 28.

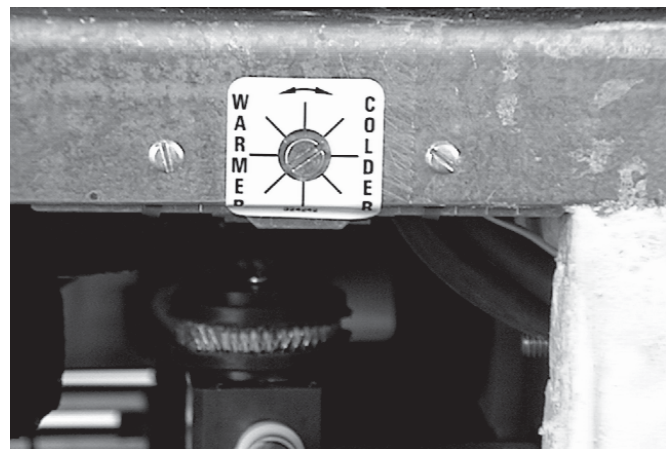

Figure 28. Temperature Control Cab

- C. Install side panel and secure with the six retaining screws.

4.7 DRIVE BELT TENSION ADJUSTMENT

To check belt tension, refer to Figure 29 and follow the steps below:



WARNING

DISCONNECT ELECTRICAL SUPPLY TO FREEZER BEFORE SERVICING.

- A. Remove either side and back panels.
- B. Press firmly on one belt. Figure 29.

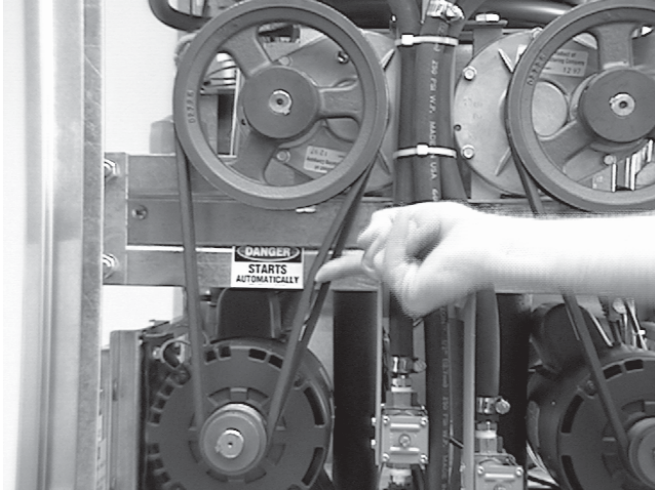

Figure 29. Belt Adjustment

- C. When the tension is properly adjusted, the outside of the depressed belt should be approximately in line with the inside of the other belt.
- D. If an adjustment is necessary, loosen the four motor plate retaining nuts, adjust belt tension then re-tighten the four nuts.

NOTE

Belt life will be increased if new drive belts are tightened after two or three weeks of operation.

4.8 CONDENSER CLEANING (AIR-COOLED FREEZERS)

The condenser requires periodic cleaning. To clean the condenser, refer to the following steps:

NOTE

Some freezers have a condenser filter, to clean remove and wash in warm soapy water. Rinse in clean water and shake dry, taking care not to damage filter in any way.

- A. Visually inspect the condenser for dirt.
- B. If the condenser is dirty, place a wet towel over the condenser.
- C. Using compressed air or CO2 tank, blow out the dirt from the back of the condenser. Most of the dirt will cling to the wet towel.



CAUTION

THIS PROCEDURE EMITS A LOUD NOISE.

- D. An alternative method is to clean with a condenser brush and vacuum.

NOTE

If the condenser is not kept clean, loss of refrigeration efficiency will result.

4.9 PREVENTATIVE MAINTENANCE

It is recommended that a preventative maintenance schedule be followed to keep the freezer clean and operating properly. The following steps are suggested as a preventative maintenance guide.



WARNING

NEVER ATTEMPT TO REPAIR OR PERFORM ANY MAINTENANCE ON FREEZER UNTIL ALL MAIN ELECTRICAL POWER HAS BEEN DISCONNECTED.

The United States Department of Agriculture and the Food and Drug Administration require that lubricants used in food zones be certified for this use. Use lubricants only in accordance with the manufacturer's instructions.

A. Daily Checks

Check for any unusual noise or condition and repair immediately.

B. Month Checks

1. Check drive belts for wear and tighten belts if necessary. (Refer to Section 4.7.)
2. Check the condenser for dirt. (Refer to Section 4.8).



WARNING

NEVER ATTEMPT TO REPAIR OR PERFORM MAINTENANCE ON FREEZER UNTIL ALL MAIN ELECTRICAL POWER HAS BEEN DISCONNECTED.

4.10 EXTENDED STORAGE

Refer to the following steps for winterizing the freezer or for storing the freezer over any long period of shutdown time.

- A. Clean thoroughly with warm detergent all parts that come in contact with mix. Rinse in clear water and dry all parts. Do not sanitize.

NOTE

Do not let cleaning solution stand in freezer barrel or mix pump during the shutdown period.

- B. Remove, disassemble, and clean the front door, auger shaft, and mix pump. Leave disassembled during the shutdown period.

- C. Place plastic auger flights in a plastic bag with a moist paper towel. This will prevent flights from becoming brittle if exposed to dry air over an extended period of time (over 30 days).

- D. For water-cooled freezers that are left in unheated buildings, or buildings subject to freezing, the water must be shut off and disconnected. Disconnect fittings at water valve inlet and water outlet lines at the freezer. The fittings are located at the rear of the freezer. Run the compressor for 2 - 3 minutes to open water valve. Blow out all water, first through water inlet, then through water outlet lines with air or carbon dioxide. Also drain water supply line to the freezer.
- E. Place the mix pump ON-OFF switch, and the CLEAN-OFF-SERVE switch in the OFF position.
- F. Disconnect from the source of electrical supply in the building.

4.11 TROUBLESHOOTING

The Troubleshooting Table lists the common problems that can occur to the freezer.

FREEZER

PROBLEM	POSSIBLE CAUSE	REMEDY
Drive motor (auger) "kicks-out", or does not run.	<ol style="list-style-type: none"> 1. Power to freezer is off. 2. Drive motor overloaded. 3. Low line voltage. 4. Product too hard. 5. Front door not installed securely. 	<ol style="list-style-type: none"> 1. Check power to freezer. 2. Wait 15-20 min. for motor to reset. 3. Check, must be +/-10% of nameplate voltage. 4. Raise overrun (see pump manual) and/or product temperature. (See Sec. 4.2) 5. Install front door securely.
Compressor does not operate.	<ol style="list-style-type: none"> 1. Power to freezer if off. 2. Drive motor overloaded. 3. Low line voltage. 4. Compressor internal overload is cut-out. 5. Front door not installed securely. 	<ol style="list-style-type: none"> 1. Check power to freezer. 2. Push DRIVE RESET lever. 3. Check, must be +/-10% of nameplate voltage. 4. Check condenser (air cooled)(See Sec. 4.4), or water supply (water cooled). 5. Install front door securely.
Product too soft.	<ol style="list-style-type: none"> 1. Temperature setting is too high. 2. Product break down. 3. Standby/Serve Switch in Standby position. 	<ol style="list-style-type: none"> 1. Adjust temperature. (See Section 4.2) 2. Fill with fresh product. 3. Place Standby/Serve Switch in Serve position.
Freeze-up. (Product will not dispense easily.)	<ol style="list-style-type: none"> 1. Temperature setting is too low. 2. Low overrun setting. 3. Low pump pressure. 4. Large air pocket in barrel. 5. Auger turning counter-clockwise. 	<ol style="list-style-type: none"> 1. Adjust temperature. (See Sec.4.2) 2. Raise overrun. (See pump manual) 3. Check pump pressure. 4. Purge air from barrel. 5. Change rotation to clockwise.
Rear auger seal leaks.	<ol style="list-style-type: none"> 1. Rear auger seal not lubricated. 2. Seal missing or installed wrong. 3. Worn or scratched shaft. 	<ol style="list-style-type: none"> 1. Lubricate seal. (See Sec. 3.14B) 2. Check. (See Sec. 3.14B) 3. Replace shaft.
Spigot leaks.	<ol style="list-style-type: none"> 1. Spigot parts are not lubricated. 2. Chipped or worn o-rings. 3. O-rings on spigot installed wrong. 4. Nicks or scratched on front door where spigot is located. 	<ol style="list-style-type: none"> 1. Lubricate. (See Sec. 3.12B) 2. Replace o-rings. 3. Remove spigot and check o-rings. 4. Replace front door.
Drive belts slipping or squealing.	<ol style="list-style-type: none"> 1. Drive belt tension not correct. 2. Worn belt(s). 3. Temperature setting is too low. 4. Low overrun. 	<ol style="list-style-type: none"> 1. Adjust belt tension. (See Sec. 4.3) 2. Replace belts. 3. Adjust temperature. (See Sec. 4.2) 4. Check for air leak.
Hopper mix temperature too warm.	<ol style="list-style-type: none"> 1. System low on refrigerant. 2. Mix level in hopper is too low. 3. EPR valve set too warm. 	<ol style="list-style-type: none"> 1. Add refrigerant. (Refrigeration Service) 2. Keep hopper 1/3 to 1/2 full of mix. 3. Remove side panel and locate EPR valve. Loosen locknut and turn screw CCW 1/4 turn. Retighten locknut. Check hopper mix temperature after one hour. Adjust another 1/4 turn if necessary.
Hopper mix temperature too cold. (sides frozen)	<ol style="list-style-type: none"> 1. EPR valve set too cold. 	<ol style="list-style-type: none"> 1. Remove side panel and locate EPR valve. Loosen locknut and turn screw CW1/4 turn. Retighten locknut. Check hopper mix temperature after one hour. Adjust another 1/4 turn if necessary.
Mix pump does not run properly.	<ol style="list-style-type: none"> 1. Mix pump problem. 	<ol style="list-style-type: none"> 1. See mix pump manual.

MIX PUMP

1. PUMP MOTOR DOES NOT RUN	
Power to pump is off.	Supply power to pump.
Low voltage.	Check for low voltage.
Mix pump hose jammed inside black cover/clamp.	Disconnect pump from power source. Remove four cover/clamp thumb screws. Separate cover/clamp halves and remove outer half. Remove jammed hose. Re-install cover/clamp and tighten four thumb screws securely. Allow motor thermal overload to reset. See Sec. 4.2 for hose replacement. Do not use jammed portion of hose.
Pump motor overloaded.	Allow internal thermal overload to reset; determine overload cause and repair.
Pressure switch on pump is defective.	Check mechanical operation and continuity of pressure switch.
Defective motor/capacitor	Check motor amperage draw and/or capacitor. Replace motor or capacitor.
Defective toggle switch.	Check continuity; repair or replace.
2. PUMP OPERATES BUT CYLINDER WILL NOT FILL	
NOTE 1: A PROPERLY WORKING PUMP WILL FILL AN 8 OZ. CUP WITH MIX IN ABOUT 9 SECONDS.	
NOTE 2: IMMEDIATELY AFTER A "BAG CHANGE" THE PUMP MAY BE UNABLE TO RE-ESTABLISH IT'S PRIME WITH THE SYSTEM AT OPERATING PRESSURE. IN THIS CASE, TURN THE PUMP OFF. DRAW 2-3 PINTS TO REDUCE SYSTEM PRESSURE TO ZERO. TURN PUMP ON. PURGE REMAINING AIR IN MIX BAG AND PICK-UP HOSE.	
IMPORTANT: Before connecting the pick-up hose to the mix bag, purge the mix bag of air to the extent possible.	
Out of Mix.	Replenish mix supply.
Mix pump hose kinked inside black cover/clamp.	Follow mix pump hose jammed repair. (See #1 above.)
Hoses assembled incorrectly.	Refer to diagram for correct hose connections.
Mix pump hose service life is exceeded.	Reposition/replace mix pump hose. See Sec. 4.2.
Mix pump hose not connected to freezer.	Connect mix pump hose to freezer.
Ice crystals in mix.	Completely thaw mix prior to use.
Mix bag drawn against adapter.	Assure bag is clear of pick-up tube.
Foreign objects in mix.	Clear blockage. Use fresh mix.
Check valve is backwards.	Observe flow arrow for proper orientation.
3. OVERRUN TOO LOW OR NO OVERRUN	
Overrun setting too low.	Increase overrun setting.
Air leak.	Tighten all hose clamps.
Air compressor not pumping air.	Contact local Stoelting Distributor.
4. OVERRUN TOO HIGH	
Mix pump hose service life is exceeded.	Reposition/replace mix pump hose.
Out of mix.	Replenish mix supply.
Overrun setting too high.	Decrease overrun setting.
Pick-up leg of mix pump hose is collapsing.	See Section 4.2.
NOTE: ALSO SEE "2" ABOVE.	

5. REPLACEMENT MIX PUMP HOSE WON'T FEED THROUGH PUMP	
Feeding hose into discharge hole of mix pump cover.	Feed hose into pick-up side of cover.
Hose ends not cut squarely.	Carefully cut hose end off squarely (no tails).
Force feeding too quickly.	Gently and slowly assist feeding of hose up into pick-up hose side of cover.
Pump motor not running.	Turn on motor switch. Also see Item 1 above.
6. AIR EXITING MIX PICK-UP HOSE	
Pickup tube check valve missing.	Contact local Stoelting Distributor.
7. DISPENSED PRODUCT AIR "POPS"	
Overrun setting too high.	Reposition/replace mix pump hose.
Mix pump hose service life is exceeded.	Reposition/replace mix pump hose.
Overdrawing the freezer's capacity.	Reduce dispense rate.
Recent "mix-out" condition.	Open spigot fully and allow excess air to "belch" out.
NOTE: ALSO SEE 2 & 4 ABOVE.	
8. MIX LEAKAGE FROM PUMP	
CAUTION: To prevent mix pump damage from dried mix deposits, immediately disassemble and clean pump.	
Mix pump hose service life is exceeded.	Remove mix pump hose. Disconnect pump from power source. Remove mix pump cover/clamp. THOROUGHLY rinse three squeeze rollers using a spray bottle filled with hot water. Thoroughly clean all mix from pump. See Sec. 4.2 for hose replacement. Lubricate squeeze roller bearings, see Item #10 below.
9. PUMP HAS POOR CAPACITY	
Lift and run limits are exceeded.	Pump is limited to 10' lift, 20' run.
NOTE: Also see 2, 4, 6 & 7.	
10. PUMP IS NOISY/SQUEAKING	
NOTE: THE ACTION OF THE AIR COMPRESSOR ROCKING ARM CREATES A REPETITIVE CLICKING SOUND DURING OPERATION. THIS IS NORMAL.	
NOTE: THE PERISTALTIC MIX PUMP HAS THREE SQUEEZE ROLLERS WHICH USE SELF LUBRICATING BEARINGS. IF SQUEAKING EXISTS WITH THE MIX PUMP HOSE IN PLACE, AND STOPS WITH THE HOSE REMOVED, THE SQUEEZE ROLLER BEARINGS CAN BE LUBRICATED USING A SILICONE BASED SPRAY. REMOVE THE MIX PUMP HOSE. DISCONNECT PUMP FROM ELECTRICAL POWER. REMOVE FOUR COVER/CLAMP THUMBSCREWS. REMOVE ENTIRE COVER/CLAMP AS ONE UNIT. SPRAY SILICONE BASED LUBRICANT ON EACH END OF EACH SQUEEZE ROLLER. SPIN ROLLERS TO WORK LUBRICANT INTO BEARINGS. REPEAT AS NEEDED.	
CAUTION: DO NOT USE CLEANING/DISSOLVING TYPE LUBRICANTS LIKE WD-40. THESE LUBRICANTS ARE NOT BEARING FRIENDLY AND WILL ACCELERATE BEARING WEAR.	
11. MIX IN AIR HOSES	
Air/mix tee above black cover/clamp.	Air/mix tee must be below black cover/clamp.
Air leak.	Tighten all hose clamps.
Mix hose on wrong air/mix tee fitting.	Refer to diagram for correct hose connections.
Pressure control manifold o-ring leak.	Check o-ring and manifold; replace as required.

SECTION 5 HOW TO ORDER REPLACEMENT PARTS

5.1 HOW TO ORDER REPLACEMENT PARTS

To assure the receipt of the proper replacement parts, supply your serviceperson with the following information:

- A. Model number of equipment.
- B. Serial number of model (stamped on nameplate)

C. Part number, part name, and quantity needed.

5.2 PARTS LIST AND REFERENCE DRAWINGS

The following lists and drawings will aid the user when ordering parts or servicing.

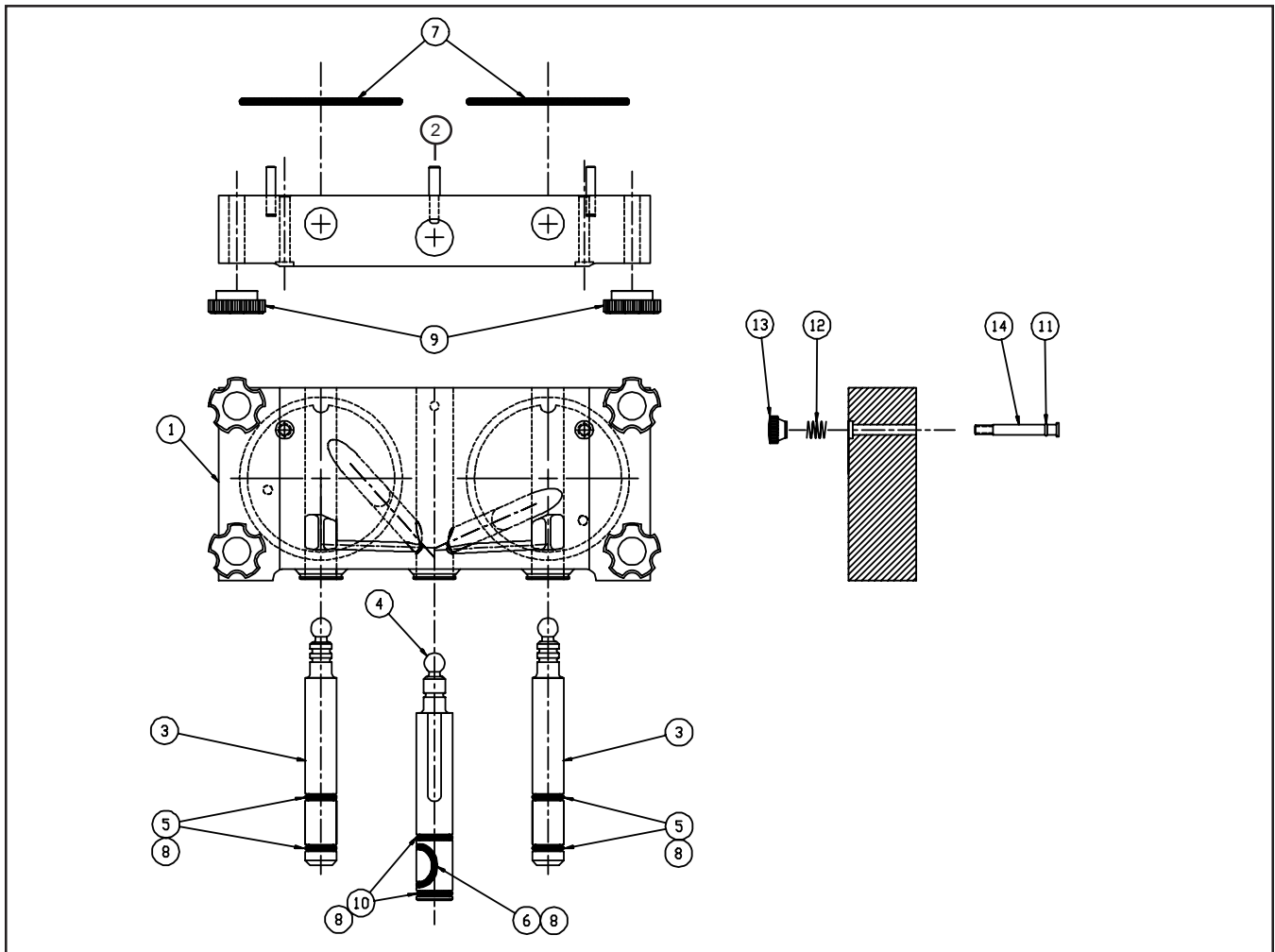

Item	Stoelting P/N	Qty.	Description
1	2177427	1	Door (Side ID Grooves)
	2177072		38mm (1.5 inch) Spigot Ext.
	2177073		64mm (2.5 inch) Spigot Ext.
	2177074		76mm (3 inch) Spigot Ext.
	232734		Rosette Cap
	624677		Castle Top O-Ring
1	2177588	1	Door w/Pins - CE
	624654		"O" Ring Spigot Extension
	2158070		38mm (1.5 inch) Spigot Ext.
	2159688		64mm (2.5 inch) Spigot Ext.
	2157869		76mm (3 inch) Spigot Ext.
	232732		Rosette Cap
	1158091	1	Actuator, Door Safety
	3159696	2	Spigot, Outside
	3158086	1	Spigot, Center
	624598	4	O-Ring
	624664	1	O-Ring (CS)
	625133	2	O-Ring (Silicone)
	508135	AsReq	Lubricant, Petrogel
	482019	4	Knob Black
	624614	2	O-Ring (CS)
	624520	2	O-Ring
	694200	2	Spring Comp.
	482004	2	Knob
	2110116	2	Valve Stem

NOTE

If you are replacing a front door without side grooves you must order the extensions and rosettes also.

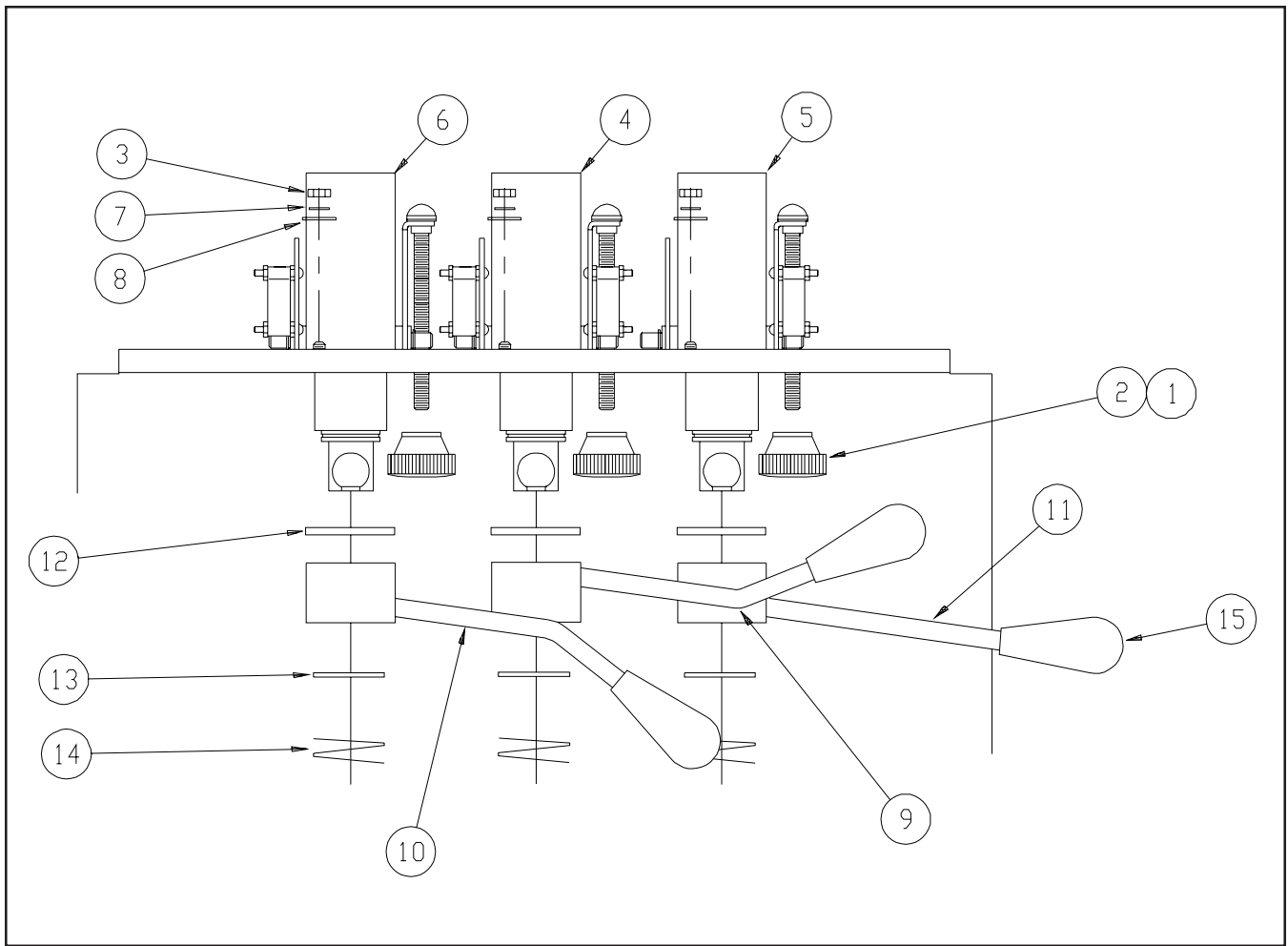

ITEM	STOELTING PN	QTY	DESCRIPTION
1	M820172	.001	ADHESIVE LOCTITE 242-31
2	482004	3	KNOB
3	538297	6	NUT HEX FULL 10-24 ZP
4	3156992	1	CAM CENTER
5	3157854	1	CAM RIGHT
6	3157855	1	CAM LEFT
7	766948	6	WASHER SHAKEPROOF 10 ZINC
8	766430	6	WASHER ROUND
9	2156997	1	HANDLE CENTER
10	2156999	1	HANDLE LEFT
11	2157850	1	HANDLE RIGHT
12	221619	3	SPACER BUSHING
13	1154703	3	WASHER
14	625440	3	RING RETAINING 1.00" DIA
15	482039	3	KNOB

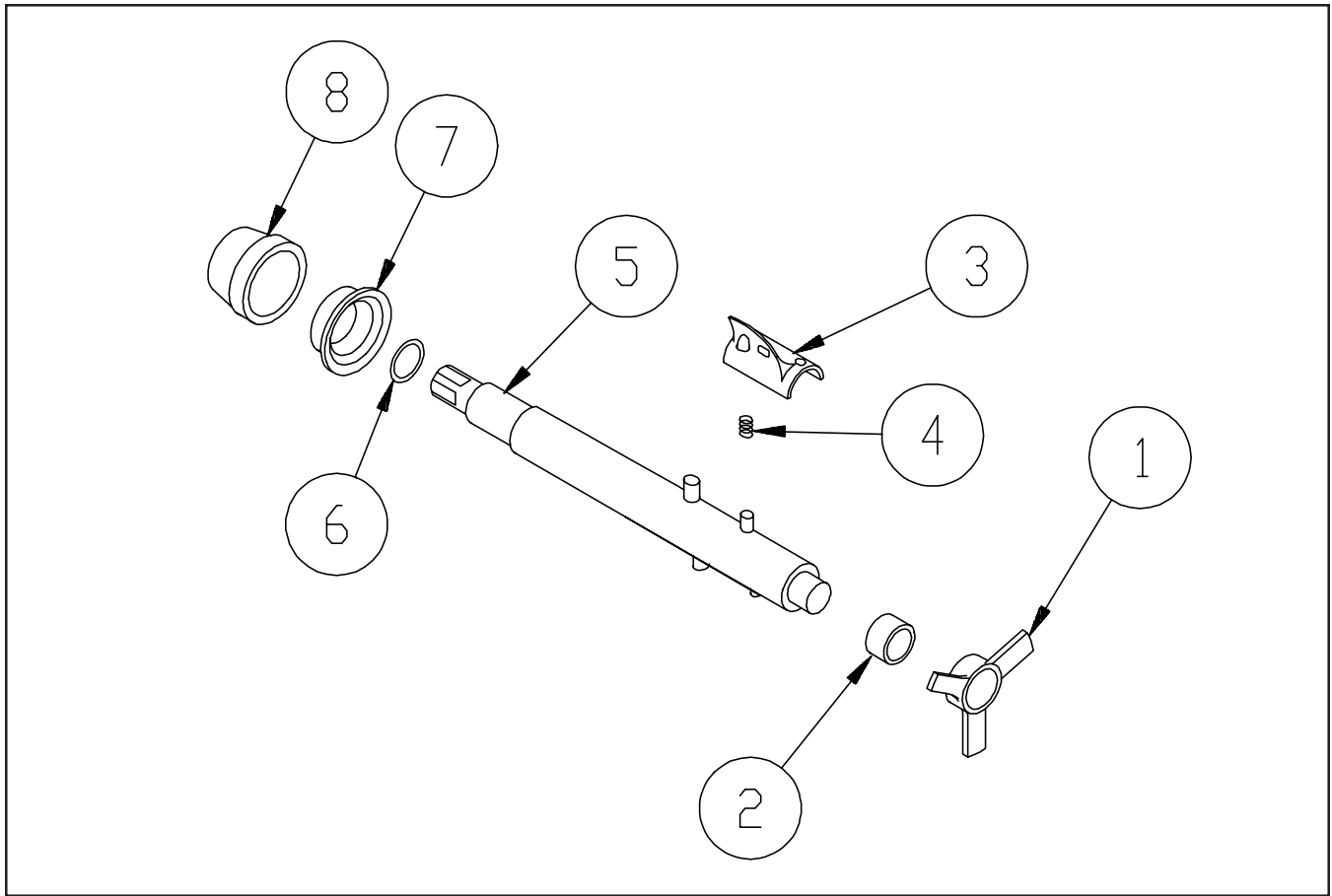

AUGER PARTS

<u>Drawing Index No.</u>	<u>Part Number</u>	<u>Qty.</u>	<u>Description</u>
1	2104552	1	Auger Front Support
2	149003	1	Front Bearing
3	381804	6	Plastic Flight
4	694255	6	Spring
5	4151178	1	Auger
6	624678	1	Rear Seal "O" Ring
7	1151859	1	Rear Seal Adaptor
8	667868	1	Rear Seal

MISCELLANEOUS PARTS

<u>Description</u>	<u>Part No.</u>
Haynes Spray 12 oz.(340 grams) -----	508017
Petro-Gel Tube 4 oz. (113 grams) -----	508135
Spline Lubricant 2 oz. (57 grams) -----	508048
Brush 4"x 8"x16" (10cm x 20cm x 40,5cm) -----	208135
Brush 2.5"x 4"x12" (6,5cm x 10cm x 30,5cm) ----	208146
Brush .25"x 4"x14" (.6cm x 10cm x 35,5cm) ----	208380
Brush 1"x3.5"x18" (2,5cm x 9cm x 45,5cm) -----	208465
Drip Tray -----	744273
Drip Tray Grid -----	417006

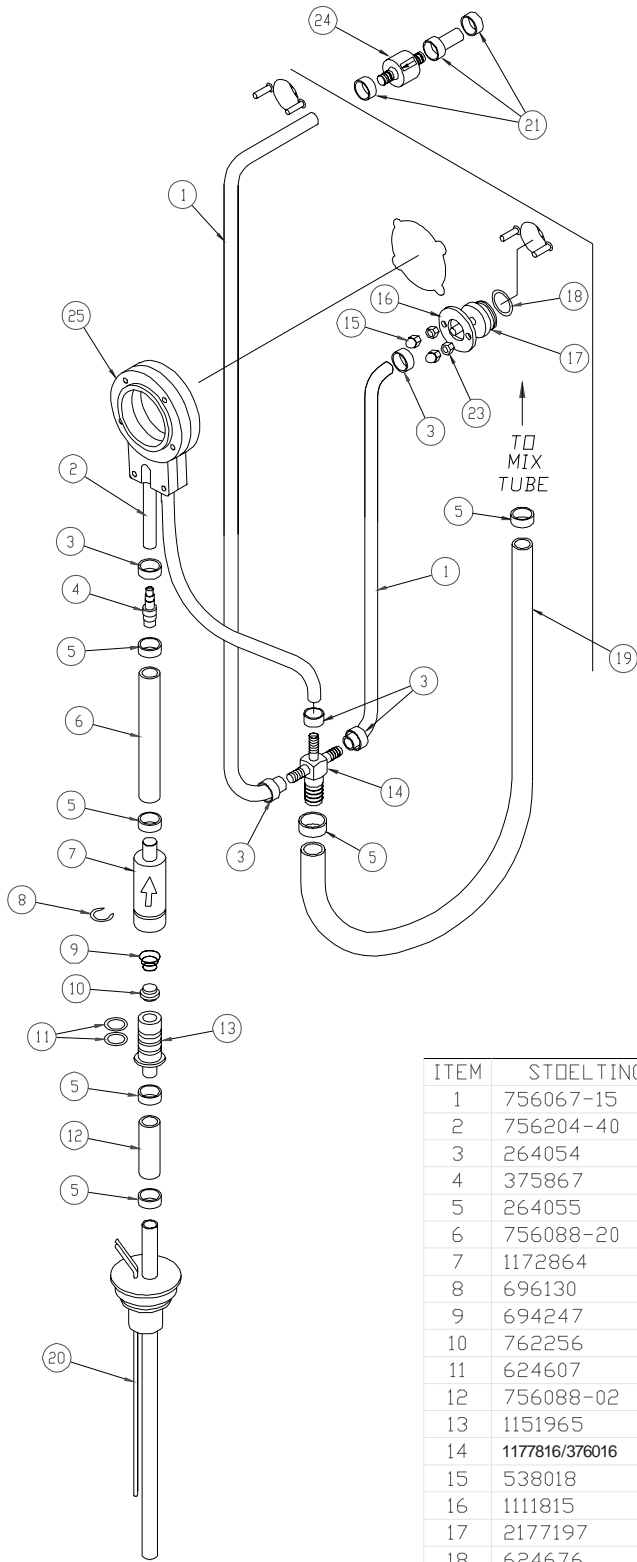

ITEM	STOELTING PN	QTY	DESCRIPTION
1	756067-15	4	TUBING PLASTIC 1/4IDX7/16OD X 15.0" LG
2	756204-40	2	TUBING NORPRENE FOOD .25 ID X 40.0" LG
3	264054	10	CLAMP LOOP JAW TYPE 7/16
4	375867	2	FITTING UNION 1/4"X1/2" BARBED
5	264055	12	CLAMP LOOP JAW TYPE 11/16
6	756088-20	2	TUBING PLASTIC 1/2IDX3/4OD X 20.0" LG
7	1172864	2	VALVE BODY - OUTER
8	696130	2	LOCK CLIP FOR VALVE
9	694247	2	SPRING COMP 13/16X3/8X3/4
10	762256	2	VALVE OUTLET CHECK (MOLDED)
11	624607	4	RING O 11/16X7/8X3/32 SPECIAL
12	756088-02	2	TUBING PLASTIC 1/2IDX3/4OD X 2.0" LG
13	1151965	2	VALVE BODY - INNER
14	1177816/376016	2	STAINLESS 4-WAY TEE
15	538018	4	NUT, 10-24 ACORN, 18-8 STN STL
16	1111815	2	LOCKING PLATE WASHER
17	2177197	2	FITTING, PRESSURE SWITCH
18	624676	2	RING O 1-1/8X1-5/16X3/32 70DUR
19	756088-30	2	TUBING PLASTIC 1/2IDX3/4OD X 30.0" LG
20	2177272	2	MIX PICKUP & PROBE ASSY
21	264235	6	CLAMP HOSE 3-8/9-16 MIN/MAX D
22	508135	.001	LUBRICANT, PETRO-GEL 4OZ.TUBES
23	538296	4	NUT HEX #10-24 X 38 SS
24	762258	2	CHECK VALVE
25	3171952	2	COVER CLAMP

Figure 7. Mix Pump

DECALS

<u>Qty.</u>	<u>Part Number</u>	<u>Description</u>
2	324200	H.P. Manual Reset
2	324798	Clean-Off-Serve
2	324797	Standby/Serve
1	324800	Cab Off-On
2	324799	Pump Off On
1	324141	Caution, Haz. Rot. Blade - Front Panel
1	324509	Cleaning - Right Side
2	324014	Auger Rotation - Evap. Enclosure Rear
4	324686	Danger - Start Auto, on Evap. Support between belts & motors support brkt.
1	723525	Winterizing, Attach to water hose near bottom
2	324106	Caution - Elec. Wiring Mat'ls must conform between water couplings, one rear panel bottom
2	324346	Caution - Haz. Mov. Parts, on inside of mtr support brkt @ rear
3	324107	Caution - Haz. Mov. Parts, on cond. bkt. rear & (2) on evap. enclosure sides
2	324208	Attn - Ref. Lk Chk, on evap. enclosure sides
2	723552	Tag - Supply volt., inside J-Box
1	723517	Card - Inside one J-Box
2		ID Tags, Back Panel Top
1	324548	Add. Vent Back Panel Ctr Top
1		Made in U.S.A. - Back panel
2	324103	Caution - Rot. Shaft, on gearbox support bracket
2	324151	Field Connections, J-Box cover, outside
3	324125	Danger Elec.Shock, J-Box covers outside, back panel bottom
1	324242	Warm/Cold, @ T-Stat
2	324565	Night/Serve - Temp. Control Bracket
2	324158	Use copper cond. only, inside both J-boxes
2	324566	Wired According to, on elec. schematic envelope
2	130000	Elec. Schematic Envelope
1	324065	Water Inlet - Back panel above inlet coupling
1	324803	Header Panel Decal (Stoelting Logo)
1	324804	Header Panel Decal (Stoelting Swirl)
1	324806	Header Panel Decal (A & W Logo)

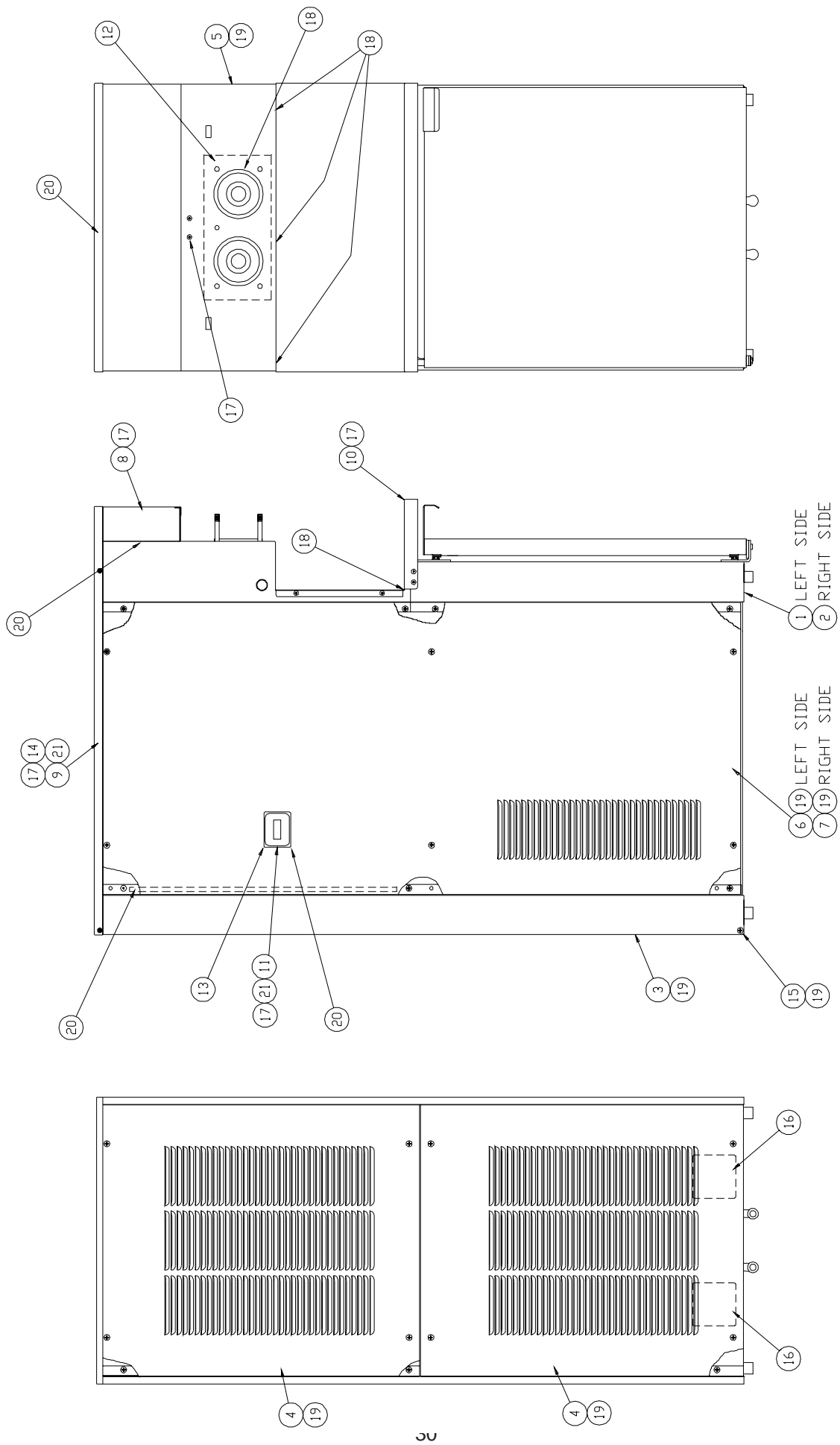

ITEM	STOELTING PN	QTY	DESCRIPTION
1	3177240	1	TRIM STRIP - LEFT
2	3177250	1	TRIM STRIP - RIGHT
3	3177236	2	TRIM STRIP - REAR
4	4177238	2	BACK PANEL
5	4177239	1	FRONT SHROUD
6	4177242	1	SIDE PANEL - LEFT
7	4177243	1	SIDE PANEL - RIGHT
8	3177244	1	HEADER PANEL
9	4177245	1	TOP PANEL, WATER COOLED
10	3177246	1	DRIP TRAY SUPPORT
11	1154886	1	SIDE PANEL COVER
12	3170804	1	GASKET INSULATION
13	744252	1	DRAIN TRAY 4231
14	4177222	1	TOP PANEL, AIR COOLED
15	538335	2	NUT HEX 1/4-20 X 7/16 STL ZP
16	314290	2	COVER SQUARE 4IN FOR OUTLET BX
17	647653	18	SCREW MACH 10-24 X 3/8 TRS HD
18	M820309	.001	SEALANT DOW CORNING ALUMINUM
19	647899	40	SCREW MACH 1/4-20 X 3/8 TRS HD
20	714003	.001	STRIP 3/8 WIDE CORK/RUBBER
21	538917	6	NUT SPEED 10-24X13/16X3/8

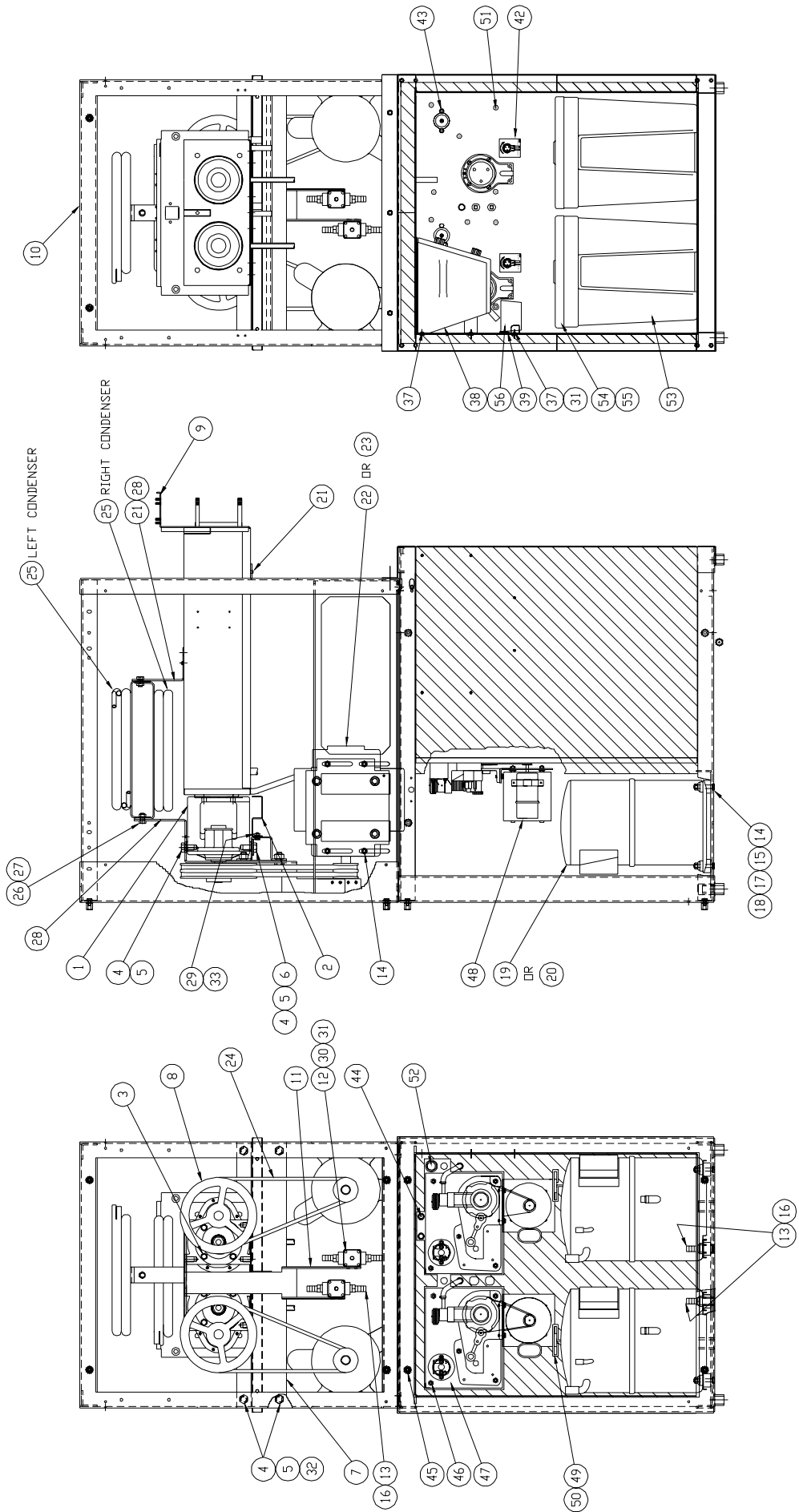

ITEM	STOELTING PN	QTY1	QTY2	DESCRIPTION
		-01	-02	
1	614231	2	2	SPEED REDUCER 5.2:1 REDUCTION
2	3177251	1	1	DRAIN TRAY SUPPORT BRACKET
3	644542	8	8	SCREW CAP 3/8-24 X 1 HX HD
4	644985	12	12	SCREW CAP 1/2-13UNC X 7/8 HX
5	766997	12	12	WASHER SHAKEPROOF 1/2X7/8
6	767226	4	4	WASHER FLT 1/2X1-3/8X9/16HV ZP
7	3177219	1	1	REDUCER SUPPORT BRACKET
8	2147034	2	2	PULLEY, 7.00 PD MACHINED
9	4177217	1	1	EVAP WELDMENT & FOAMED
10	4177208	1	1	FRAME WELDMENT
11	2177225	1	1	WATER VALVE BRACKET
12	763181	2	2	VALVE WATER 3/8NPT
13	369833	6	6	FITTING,BARBED 1/2X3/8 BRASS
14	538351	16	16	NUT HEX 5/16-18 LOCKING FLANGE
15	422156	2	2	GROMMET KIT WITH SLEEVES
16	728190	.001	.001	TEFLON THRD SEAL TAPE 520"/ROL
17	644371	8	8	SCREW CAP 5/16-18 X 1-3/4 HX
18	767211	8	8	WASHER FLAT 5/16,7/8X3/8X14GA
19	282025	2	.	COMPRESSOR, 208-230/60/1PH
20	282026	.	2	COMPRESSOR, 208-230/60/3PH
21	649081	5	5	SCREW DRILL & TAP 8-18 X 1/2
22	522869	.	2	DRIVE MOTOR 3PH
23	522844	2	.	DRIVE MOTOR 1PH (SER #0-16058)
23	522856	2	.	DRIVE MOTOR 1PH (SER #16059 PLUS)
24	152294	4	4	BELT V 39.2 O.L. X 38.3 P.L.
25	284104	2	2	WATER COOLED CONDENSER
26	538356	2	2	3/8-16 NUT HEX LOCKING FLANGE ZP
27	644522	2	2	SCREW CAP 3/8-16 X 3/4 HX HD
28	2177226	2	2	WATER CONDENSER BRACKET
29	644091	2	2	SCREW CAP 1/4-20 X 1/2 HX HD
30	644024	4	4	SCREW MACH 8-32 X 1/4 HX HD ZP
31	M820172	.001	.001	LOCTITE ADHESIVE #242 BLUE
32	538395	4	4	NUT HEX 1/2-13X3/4X5/16 ZP
33	538335	2	2	1/4-20 SPIN L/N ZC
34	714003	.001	.001	3/8" X 100' ROLL/RUBBER
35	628007	5	5	RIVET 1/8"
36	524091	5	5	MOUNT TIE
37	647653	6	6	SCREW MACH 10-24 X 3/8 TRS HD
38	3177257	1	1	CAB EVAPORATOR ASSY
39	2177235	1	1	BRACKET, DRIP TRAY, CAB
40	M850004	ASREQ	ASREQ	RTV DOW CORNING 734
41	M980178	ASREQ	ASREQ	PERMAGUM
42	324724	2	2	DECAL, TUBE FEED
43	538296	4	4	NUT HEX #10-24 X 3/8 SS
44	422057	2	2	GROMMET RBR 3/8X5/8X1/4X1/16
45	717917-SV	2	2	SWITCH, AIR PRESSURE
46	538335	10	10	NUT HEX 1/4-20 X 7/16 STL ZP
47	3177221	2	2	PLATE, PUMP MOUNTING
48	522229	2	2	PUMP MOTOR, ONLY
49	266018	2	2	CLIP ADHESIVE BACKED "J"
50	778027	2	2	WRENCH, ALLEN 5/32 X 3.0 LG.
51	647915	10	10	SCREW MACH 1/4-20 X 7/8 TRS HD SSSL
52	422074	1	1	GROMMET RUBBER BLACK
53	558113	2	2	PAN, MIX CONTAINER
54	3177262	2	2	COVER, FRONT
55	3177229	2	2	COVER, REAR
56	744272	1	1	DRIP TRAY, CAB

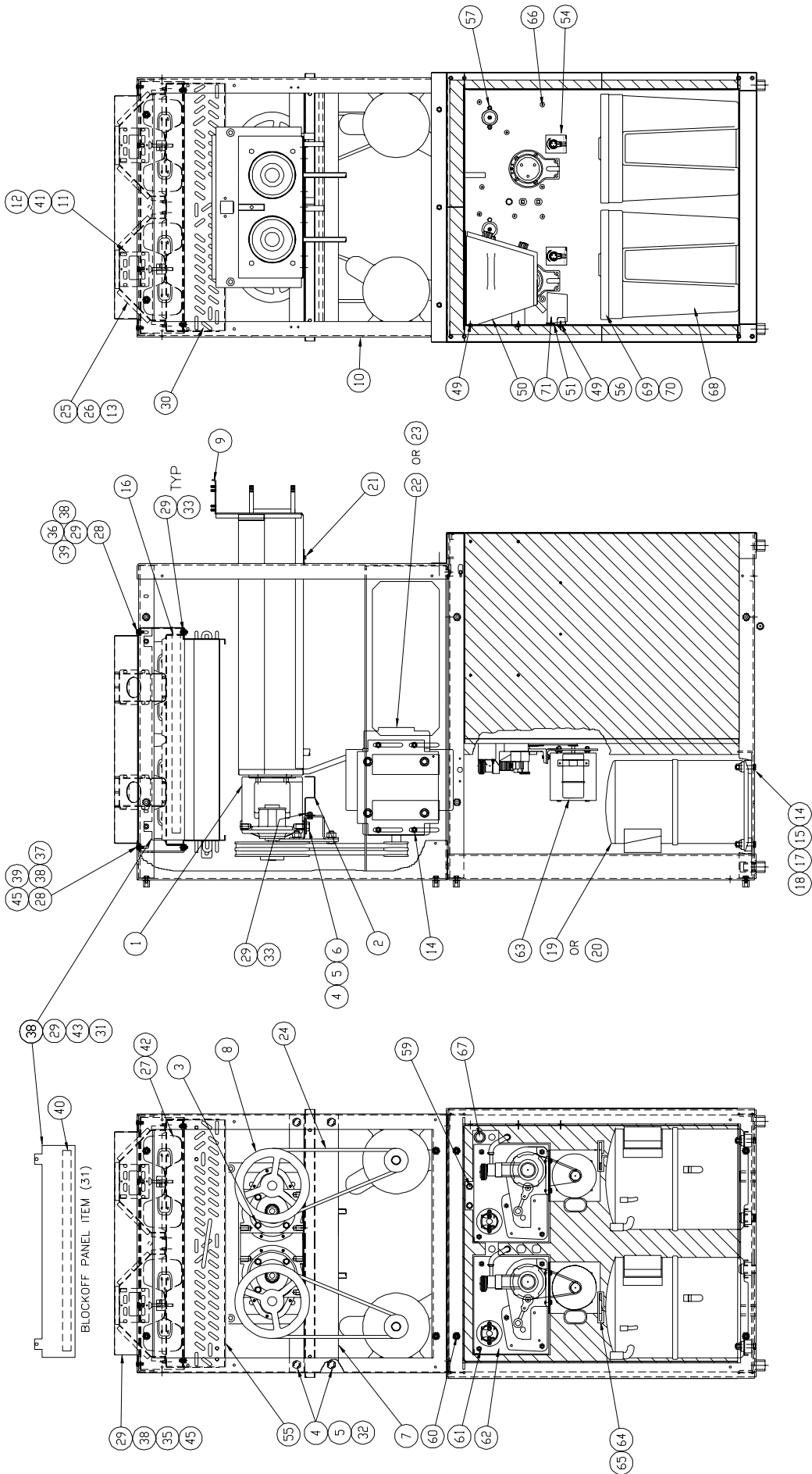

ITEM	STOELTING PN	QTY1	QTY2	DESCRIPTION
		-01	-02	
1	614231	2	2	SPEED REDUCER 5.2:1 REDUCTION
2	3177251	1	1	DRAIN TRAY SUPPORT BRACKET
3	644542	8	8	SCREW CAP 3/8-24 X 1 HX HD
4	644985	8	8	SCREW CAP 1/2-13UNC X 7/8 HX
5	766997	8	8	WASHER SHAKEPROOF 1/2X7/8
6	767226	4	4	WASHER FLT 1/2X1-3/8X9/16HV ZP
7	3177219	1	1	REDUCER SUPPORT BRACKET
8	2147034	2	2	PULLEY, 7.00 PD MACHINED
9	4177217	1	1	EVAP WELDMENT & FOAMED
10	4177208	1	1	FRAME WELDMENT
11	522833	4	4	FAN MOTOR
12	538280	16	16	NUT, #8-32
13	766948	16	16	WASHER #10 SHAKEPROOF
14	538351	16	16	NUT HEX 5/16-18 LOCKING FLANGE
15	422156	2	2	GROMMET KIT WITH SLEEVES
16	4177262	1	1	CONDENSER SHROUD
17	644371	8	8	SCREW CAP 5/16-18 X 1-3/4 HX
18	767211	8	8	WASHER FLAT 5/16,7/8X3/8X14GA
19	282025	2	.	COMPRESSOR, 208-230/60/1PH
20	282026	.	2	COMPRESSOR, 208-230/60/3PH
21	649081	3	3	SCREW DRILL & TAP 8-18 X 1/2
22	522869	.	2	DRIVE MOTOR 3PH
23	522844	2	.	DRIVE MOTOR 1PH (SER #0-16058)
23	522856	2	.	DRIVE MOTOR 1PH (SER #16059 PLUS))
24	152294	4	4	BELT V 39.2 O.L. X 38.3 P.L.
25	3171824	4	4	FAN MOTOR BRACKET
26	538297	16	16	NUT, 10-24 ZC
27	162067	4	4	FAN BLADE 9"
28	4177261	2	2	CONDENSER BRACKET
29	644091	14	14	SCREW CAP 1/4-20 X 1/2 HX HD
30	284082	1	1	CONDENSER
31	2177069	2	2	BLOCKOFF PANEL
32	538395	4	4	NUT HEX 1/2-13X3/4X5/16 ZP
33	538335	6	6	1/4-20 SPIN L/N ZC
34	463010	8	8	THREADED INSERT, 1/4-20
35	4177070	1	1	UPPER BLOCKOFF PANEL
36	222997	1	1	BUSHING SNAP 9/32 ID, 3/8 HOLE
37	584200-04	1	1	PLUG HOLE .375 DIA MTG HOLE
38	766964	12	12	WASHER SHAKEPROOF 1/4 ZINC
39	766456	4	4	WASHER ROUND 5/8X9/32 STEEL
40	M820323	.001	.001	TAPE INSUL 1 X 1/4 IN THICK
41	766940	16	16	WASHER SHAKEPROOF 8 ZINC PLATE
42	M820172	.001	.001	ADHESIVE LOCTITE 242-31
43	538928	4	4	NUT SPEED 1/4-20X63/64X1/2
44	714006	.001	.001	1" X 100' ROLL/RUBBER
45	644106	4	4	SCREW CAP 1/4-20 X 5/8 HX HD
46	714003	.001	.001	3/8" X 100' ROLL/RUBBER
47	628007	5	5	RIVET 1/8"
48	524091	5	5	MOUNT TIE
49	647653	6	6	SCREW MACH 10-24 X 3/8 TRS HD
50	3177257	1	1	CAB EVAPORATOR ASSY
51	2177235	1	1	BRACKET, DRIP TRAY, CAB
52	M850004	ASREQ	ASREQ	RTV DOW CORNING 734
53	M980178	ASREQ	ASREQ	PERMAGUM
54	324724	2	2	DECAL, TUBE FEED
55	368102	2	2	FILTER AIR
56	M820172	.001	.001	ADHESIVE LOCTITE 242-31
57	538296	4	4	NUT HEX #10-24 X 3/8 SS
58	223005	2	2	BUSHING, SNAP 1/2 ID .625 HOLE
59	422057	2	2	GROMMET RBR 3/8X5/8X1/4X1/16
60	717917-SV	2	2	SWITCH, AIR PRESSURE
61	538335	10	10	NUT HEX 1/4-20 X 7/16 STL ZP
62	3177221	2	2	PLATE, PUMP MOUNTING
63	522229	2	2	PUMP MOTOR ONLY
64	266018	2	2	CLIP ADHESIVE BACKED "J"
65	778027	2	2	WRENCH, ALLEN 5/32 X 3.0 LG.
66	647915	10	10	SCREW MACH 1/4-20 X 7/8 TRS HD SSTL
67	422074	1	1	GROMMET RUBBER BLACK
68	558113	2	2	PAN, MIX CONTAINER
69	3177262	2	2	COVER, FRONT
70	3177229	2	2	COVER, REAR
71	744272	1	1	DRIP TRAY, CAB

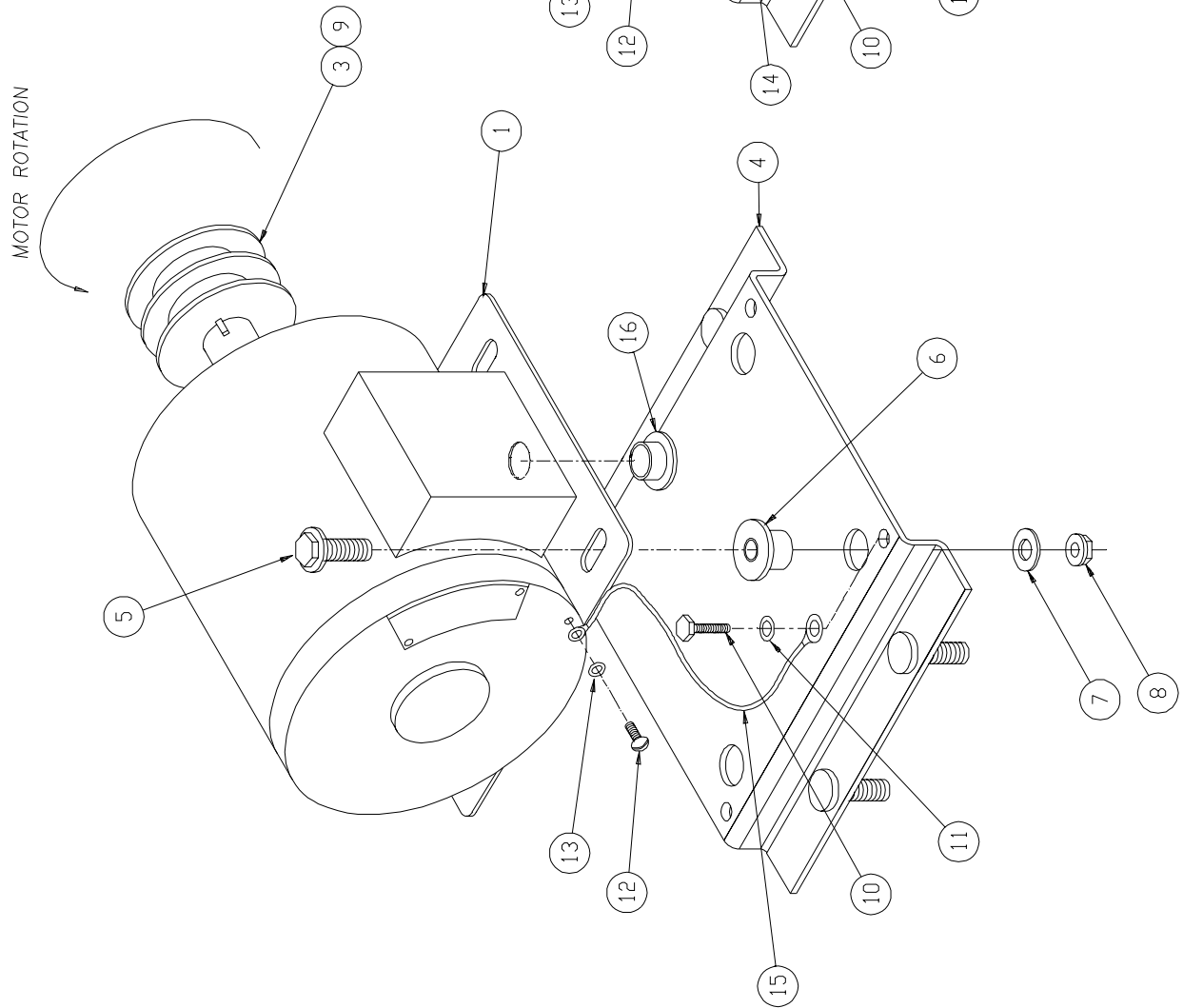
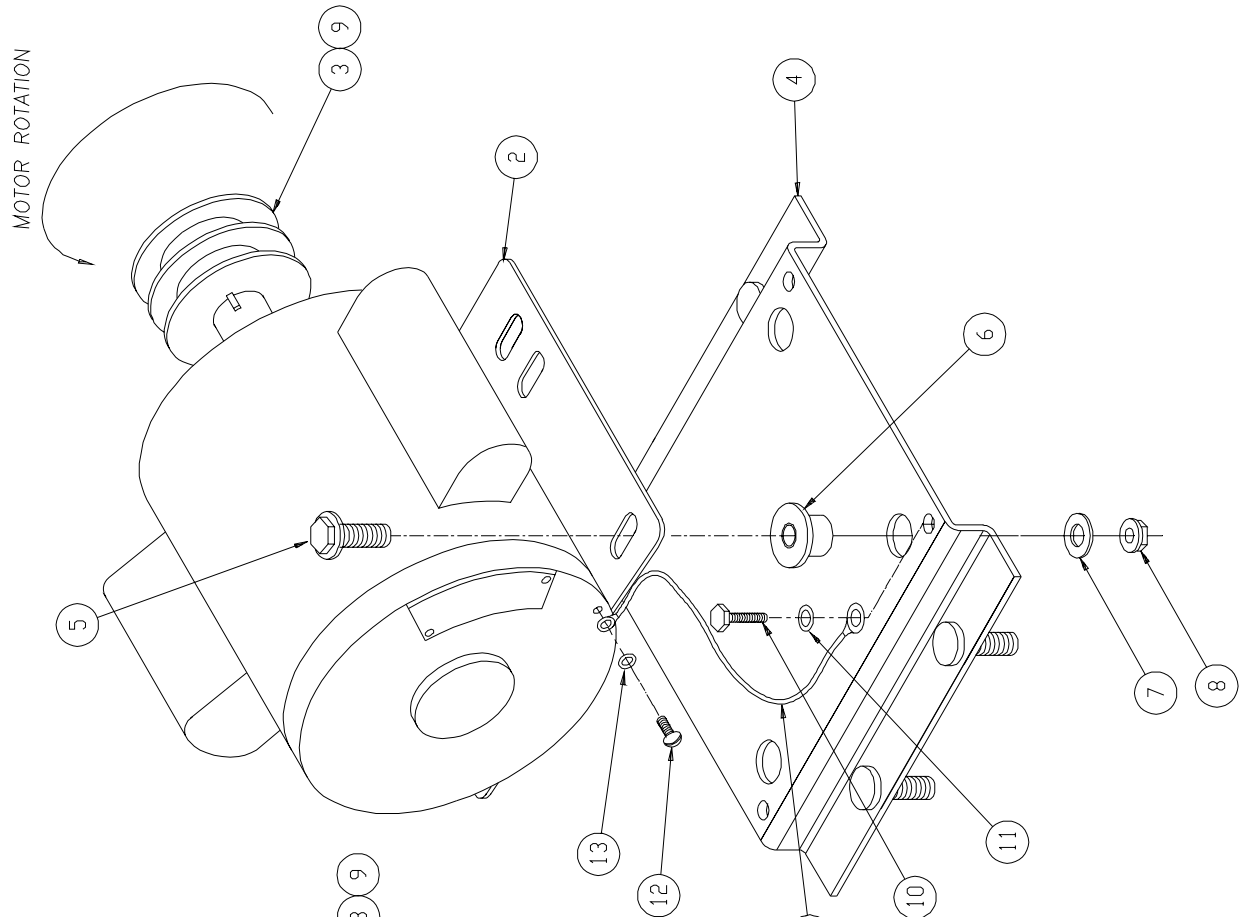

ITEM	STOELTING PN	QTY	DESCRIPTION
1	522869	1	MOTOR 2HP 208-230/60/3 1740RPM
2	522844	1	MOTOR 2HP 208-230/60/1 1740RPM
			SERIAL #0-16058
2	522856	1	MOTOR 2HP 208-230/60/1 1740RPM
			SERIAL #16059 PLUS
3	2117987	1	PULLEY 2 GROOVE 2.10 A.P.D.
4	2177223	1	MOTOR MOUNTING PLATE WELD'T
5	644328	4	SCREW CAP 5/16-18 X 1 HX HD ZP
6	524035	4	MOUNT MOTOR RUBBER 1.0 X .75
7	766496	4	WASHER,FENDER 5/16 X 1-1/4 DD
8	538351	4	NUT HEX 5/16-18 LOCKING FLANGE
9	650333	1	SCREW SSS 5/16-18NC X 3/8 DV
10	649107	1	SCREW TAP 10-16 X 1/2 HX HD ZP
11	766940	1	WASHER SHAKEPROOF 8 ZINC PLATE
12	649104	1	SCREW TAP 10-24 X 3/8 RD HD PH
13	766948	1	WASHER SHAKEPROOF 10 ZINC
14	430028	1	WNP04D2T HARNESS
15	430255	1	WPP08E2T HARNESS
16	223058	1	BUSHING SNAP 11/16 ID HOLE 7/8

ITEM	STOELTING PN	QTY	DESCRIPTION
1	442191-L	1	HINGE, LOWER LEFT
2	442192-L	1	HINGE, UPPER LEFT
3	3177231	1	HANDLE, CAB DOOR
4	644093	4	SCREW CAP 1/4-20 X 1/2 HX HD
5	647671	4	SCREW MACH 10-24 X 1/2 FL HD
6	4177232	1	DOOR, CAB
7	647653	4	SCREW MACH 10-24 X 3/8 TRS HD
8	584200-10	1	PLUG HOLE .750 DIA MTG HOLE

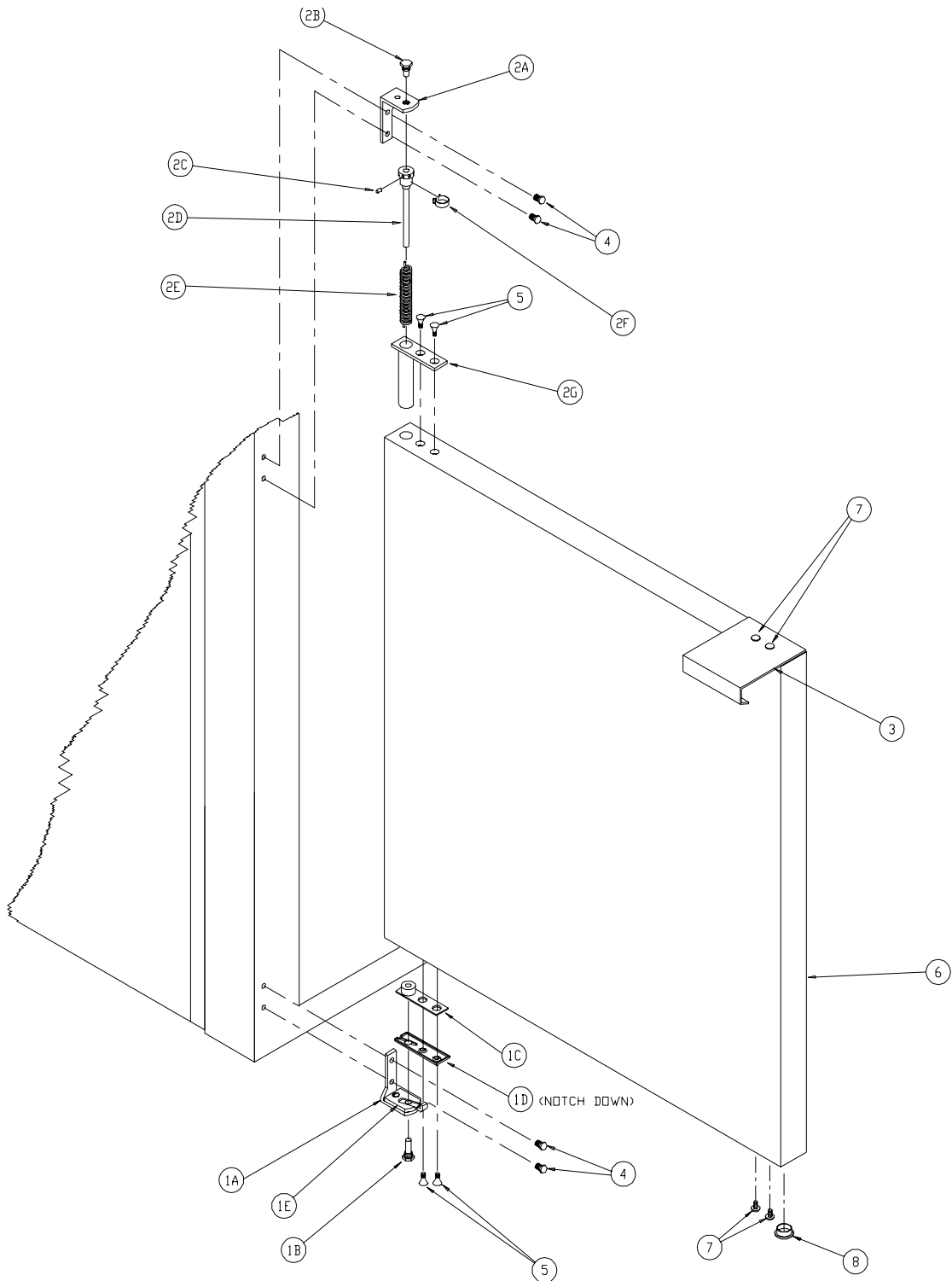

ITEM	STOELTING PN	QTY1	QTY2	DESCRIPTION
1	739527	2	2	TIMER,INTERVAL 24 VAC
2	647529	7	7	SCREW MACH 8-32 X 1/2 RD HD PH
3
4	732010	3	3	TERMINAL BLOCK
5	223007	4	4	BUSHING SNAP 5/8ID 3/4 MTG
6	591001	4	4	POTENTIOMETER
7	324565	2	2	DECAL-TEMPERATURE ADJUSTMENT
8	3177252	2	2	BRACKET, TEMP CONTROL
9	1172733	2	2	CONTRDL TEMP W/EXTERNAL SWITCH
10	647658	11	9	SCREW MACH 10-24 X 3/8 RD HD
11	766948	22	20	WASHER SHAKEPROOF 10 ZINC
12	295109	5	5	CONTACTOR MAG 3-POLE 24V
13	524087	8	8	MOJUNT DUAL LOCK CIRCUIT SPACER
14	618142	2	0	RELAY MOTOR START (COPE-COMP)
15	2177218	2	2	TRANSFORMER ASSY
16	223015	1	1	BUSHING SNAP 1-1/8 MTG HOLE
17	231057	2	0	CAPACITOR RUN 35 MFD 370VAC
18	231058	2	0	CAPACITOR START 145/174 MFD
19	714006	1.50 FT	1.50 FT	1" X 100' ROLL/RUBBER
20	2156689	4	0	CAPACITOR BRACKET (2.0 DIA)
21	4177237	1	1	ELECTRICAL PANEL
22	714003	1.67 FT	1.67 FT	STRIP 3/8 WIDE CORK/RUBBER
23	647393	2	0	SCREW MACH 6-32 X 3/8 RD HD PH
24	295011	1	1	CONTACTOR MAGNETIC 2 POLE
25	672680	1	1	SENSOR, CURRENT, 24VAC (AC ONLY)
26	324728	1	1	DECALS, CONTACTOR IDENT.
27	647641	12	12	SCREW MACH 10-24 X 1/4 RD HD
34	618231	0	2	OVERLOAD RELAY 3.7-12 AMP
35	2177911	0	2	BRACKET OVERLOAD RELAY
36	647536	0	2	E*SCREW MACH 8-32 X 5/8 RD PH
37	766941	0	2	E*WASHER SHAKEPROOF #8
38	538297	0	4	NUT HEX FULL 10-24 ZP

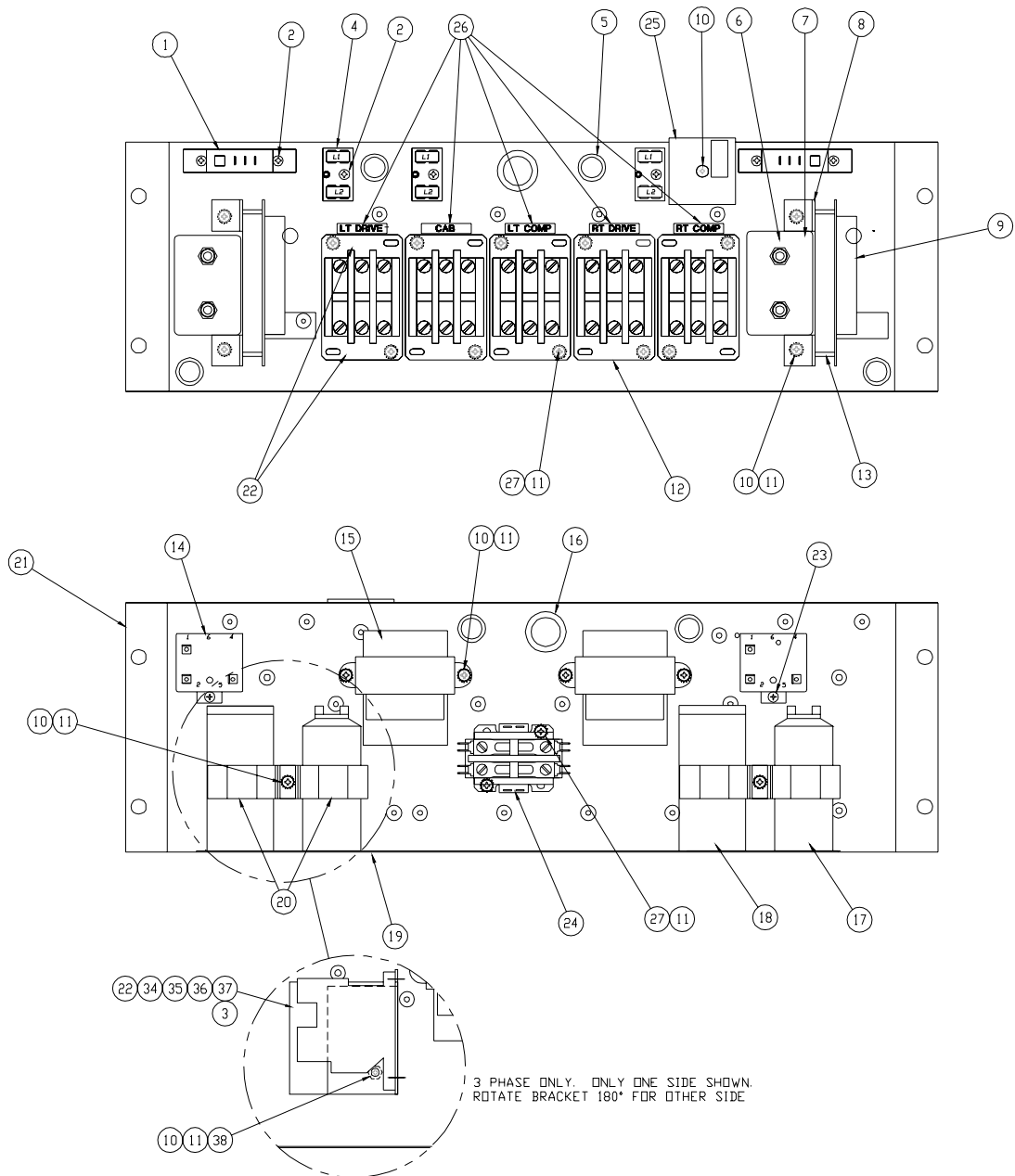

3 PHASE ONLY. ONLY ONE SIDE SHOWN.
 ROTATE BRACKET 180° FOR OTHER SIDE

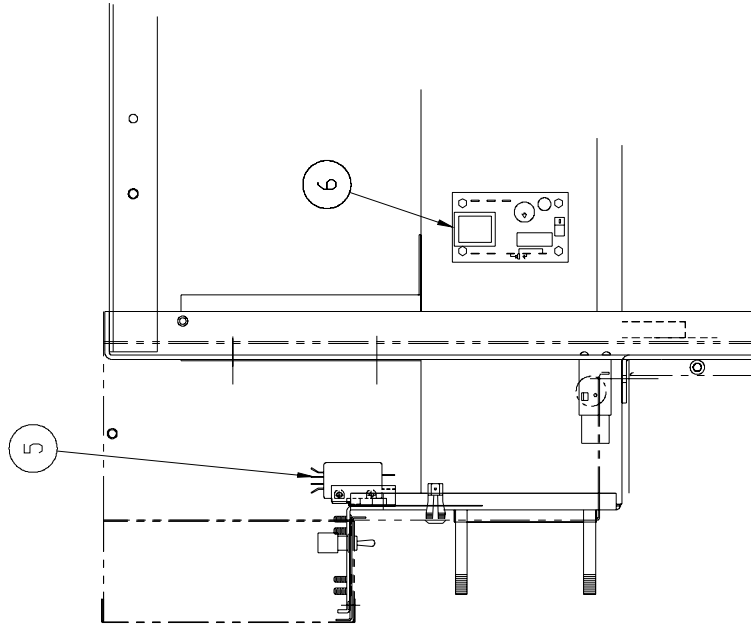
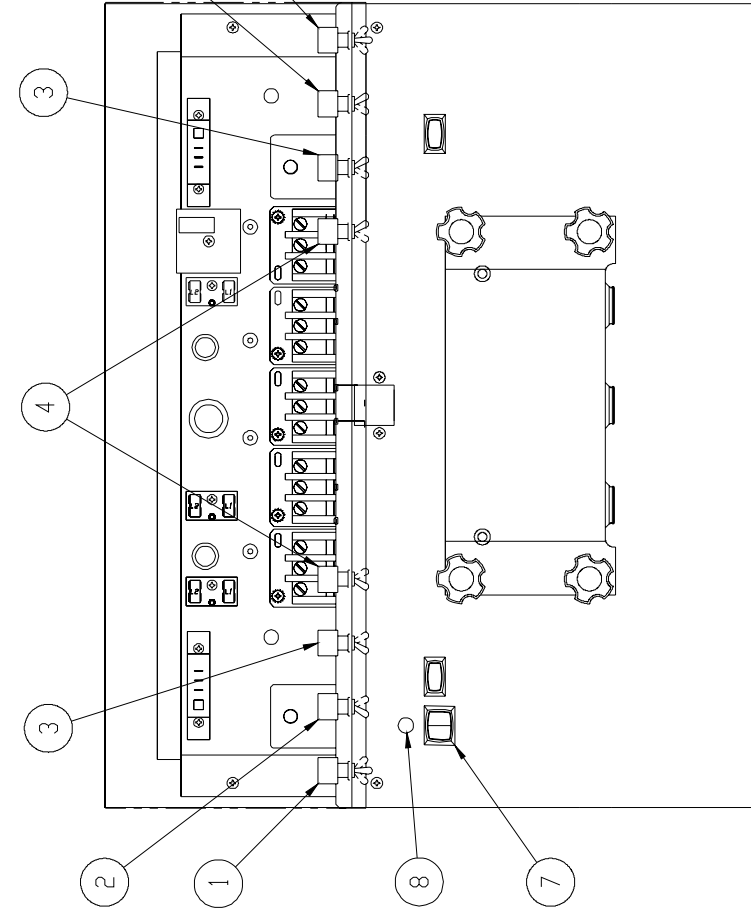

ITEM	STOELTING PN	QTY	DESCRIPTION
1	718534	2	SWITCH TOGGLE (CLEAN OFF ON)
2	718539	2	SWITCH TOGGLE (NIGHT SERVE)
3		2	SWITCH TOGGLE (FORCED REFRIGERATION)
4	718532	2	SWITCH TOGGLE (PUMP)
5	718776	1	SWITCH, LIMIT (DOOR SAFETY)
6	296179	2	CONTROL LIQUID LEVEL 24V
7	718895	1	SWITCH, CAB ON - OFF
8	493042	1	LIGHT, INDICATOR

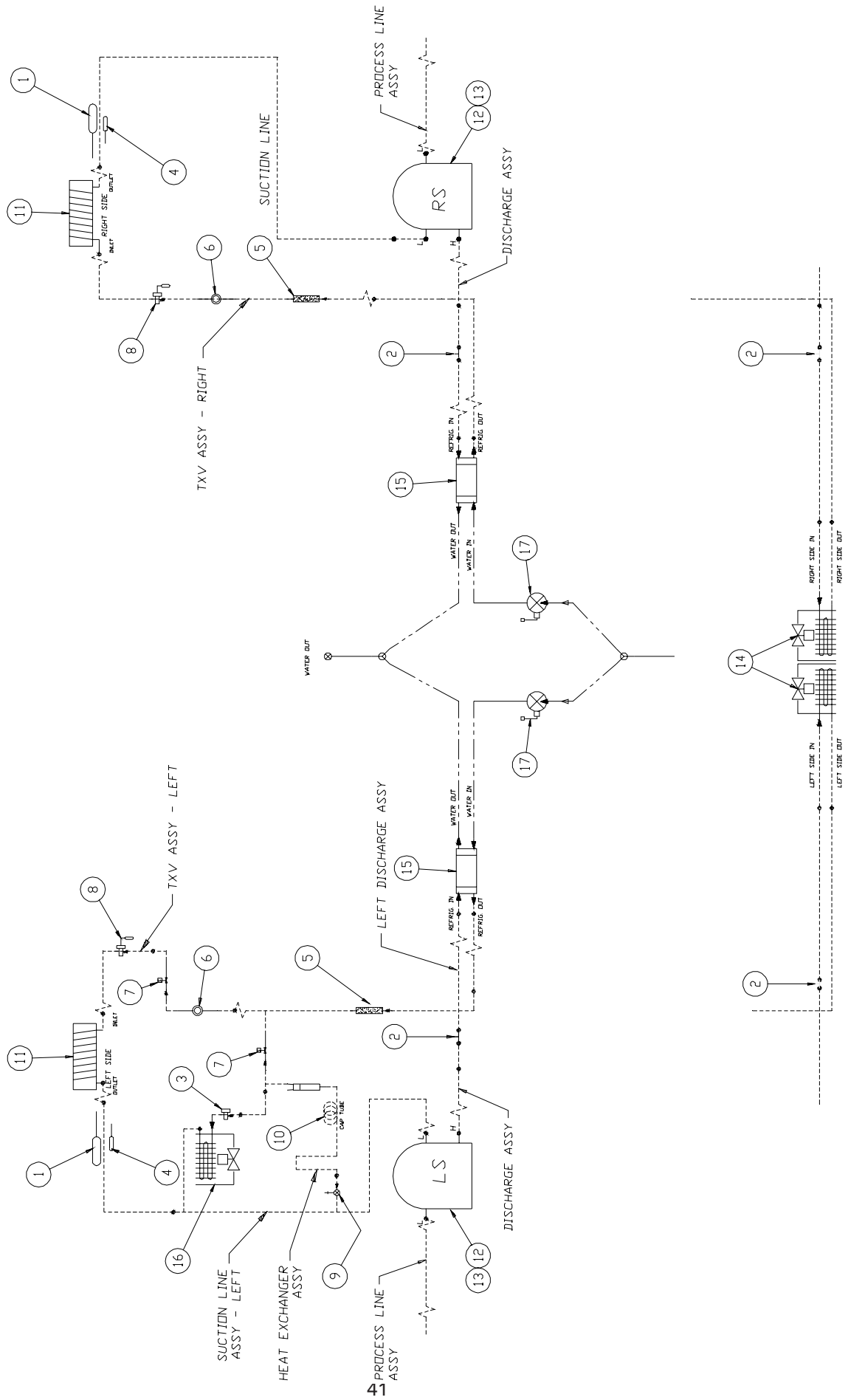

ITEM	STDELTING PN	QTY	DESCRIPTION
1	4172725	2	BULB & SENSOR MOUNTING ASSY
2	718710	2	SWITCH PRESSURE
3	762410	1	VALVE, EXPANSION ADJUSTABLE - CAB
4	1172731	2	THERMISTOR PROBE ASSEMBLY
5	342008	2	DRIER, FILTER
6	458009	2	INDICATOR SIGHTGLASS
7	763455	2	VALVE SOLENOID
8	762412	2	VALVE, TXV 1/2 TON
9	762978	1	VALVE EPR R22
10	231101 - SV	1	CAPILLARY TUBE .072X.026
11	4177217	1	EVAP WELDMENT & FOAMED
12	282025	2	COMPRESSOR, 208-230/60/1PH
13	282026	2	COMPRESSOR, 208-230/60/3PH
14	284082	1	CONDENSER, AIR-COOLED
15	284104	1	CONDENSER, WATER-COOLED
16	355002	1	CAB EVAPORATOR
17	763181	2	VALVE, WATER 3/8 NPT



WARRANTY SOFT SERVE / SHAKE FREEZERS

1. Scope:

Stoelting, LLC warrants to the first user (the “Buyer”) that the freezer cylinders, hoppers, compressors, drive motors, speed reducers, auger and auger flights of Stoelting soft serve / shake freezers will be free from defects in materials and workmanship under normal use and proper maintenance appearing within five (5) years, and that all other components of such equipment manufactured by Stoelting will be free from defects in material and workmanship under normal use and proper maintenance appearing within twelve (12) months after the date that such equipment is originally installed.

2. Disclaimer of Other Warranties:

THIS WARRANTY IS EXCLUSIVE; AND STOELTING HEREBY DISCLAIMS ANY IMPLIED WARRANTY OF MERCHANTABILITY OR FITNESS FOR PARTICULAR PURPOSE.

3. Remedies:

Stoelting’s sole obligations, and Buyer’s sole remedies, for any breach of this warranty shall be the repair or (at Stoelting’s option) replacement of the affected component at Stoelting’s plant in Kiel, Wisconsin, or (again, at Stoelting’s option) refund of the purchase price of the affected equipment, and, during the first twelve (12) months of the warranty period, deinstallation/reinstallation of the affected component from/into the equipment. Those obligations/remedies are subject to the conditions that Buyer (a) signs and returns to Stoelting, upon installation, the Checklist/Warranty Registration Card for the affected equipment, (b) gives Stoelting prompt written notice of any claimed breach of warranty within the applicable warranty period, and (c) delivers the affected equipment to Stoelting or its designated service location, in its original packaging/crating, also within that period. Buyer shall bear the cost and risk of shipping to and from Stoelting’s plant or designated service location.

4. Exclusions and Limitations:

This warranty does not extend to parts, sometimes called “wear parts”, which are generally expected to deteriorate and to require replacement as equipment is used, including as examples but not intended to be limited to o-rings, auger seals, auger support bushings and drive belts. All such parts are sold

AS IS.

Further, Stoelting shall not be responsible to provide any remedy under this warranty with respect to any component that fails by reason of negligence, abnormal use, misuse or abuse, use with parts or equipment not manufactured or supplied by Stoelting, or damage in transit.

THE REMEDIES SET FORTH IN THIS WARRANTY SHALL BE THE SOLE LIABILITY STOELTING AND THE EXCLUSIVE REMEDY OF BUYER WITH RESPECT TO EQUIPMENT SUPPLIED BY STOELTING; AND IN NO EVENT SHALL STOELTING BE LIABLE FOR ANY INCIDENTAL OR CONSEQUENTIAL DAMAGES, WHETHER FOR BREACH OF WARRANTY OR OTHER CONTRACT BREACH, NEGLIGENCE OR OTHER TORT, OR ON ANY STRICT LIABILITY THEORY.

